



US009345886B2

(12) **United States Patent**
Kilgard et al.

(10) **Patent No.:** **US 9,345,886 B2**

(45) **Date of Patent:** **May 24, 2016**

(54) **TIMING CONTROL FOR PAIRED PLASTICITY**
(71) Applicants: **MicroTransponder, Inc.**, Austin, TX (US); **The Board of Regents, The University of Texas System**, Austin, TX (US)

(72) Inventors: **Michael P. Kilgard**, Richardson, TX (US); **Larry Cauller**, Plano, TX (US); **Navzer Engineer**, Plano, TX (US); **Christa McIntyre Rodriguez**, Richardson, TX (US); **Will Rosellini**, Dallas, TX (US)

(73) Assignees: **MICROTRANSPONDER, INC.**, Austin, TX (US); **THE BOARD OF REGENTS, THE UNIVERSITY OF TEXAS SYSTEM**, Austin, TX (US)

(*) Notice: Subject to any disclaimer, the term of this patent is extended or adjusted under 35 U.S.C. 154(b) by 67 days.

(21) Appl. No.: **14/497,907**

(22) Filed: **Sep. 26, 2014**

(65) **Prior Publication Data**
US 2015/0012054 A1 Jan. 8, 2015

Related U.S. Application Data

(60) Continuation of application No. 13/941,986, filed on Jul. 15, 2013, which is a division of application No. (Continued)

(51) **Int. Cl.**
A61N 1/00 (2006.01)
A61N 1/36 (2006.01)
(Continued)

(52) **U.S. Cl.**
CPC **A61N 1/36167** (2013.01); **A61F 11/00** (2013.01); **A61M 21/00** (2013.01);
(Continued)

(58) **Field of Classification Search**
CPC A61N 1/36053; A61N 1/36092; A61N 1/37235; A61N 1/36103; A61N 1/36003; A61N 1/36167
USPC 607/1-3, 45
See application file for complete search history.

(56) **References Cited**
U.S. PATENT DOCUMENTS

2,641,259 A 6/1953 Bartrow
3,750,653 A 8/1973 Simon
(Continued)

FOREIGN PATENT DOCUMENTS

CN 101648053 A 2/2010
DE 3405630 C1 6/1985
(Continued)

OTHER PUBLICATIONS

Sawan, M., "Wireless Smart Implants Dedicated to Multichannel Monitoring and Microstimulation," IEEE/ACS International Conference on Pervasive Services, Jul. 2004, pp. 21-26, Abstract.
(Continued)

Primary Examiner — Niketa Patel
Assistant Examiner — Mallika D Fairchild
(74) *Attorney, Agent, or Firm* — Lowe Hauptman & Ham, LLP

(57) **ABSTRACT**
Systems, methods and devices for paired training include timing controls so that training and neural stimulation can be provided simultaneously. Paired trainings may include therapies, rehabilitation and performance enhancement training. Stimulations of nerves such as the vagus nerve that affect subcortical regions such as the nucleus basalis, locus coeruleus or amygdala induce plasticity in the brain, enhancing the effects of a variety of therapies, such as those used to treat tinnitus, stroke, traumatic brain injury and post-traumatic stress disorder.

19 Claims, 7 Drawing Sheets

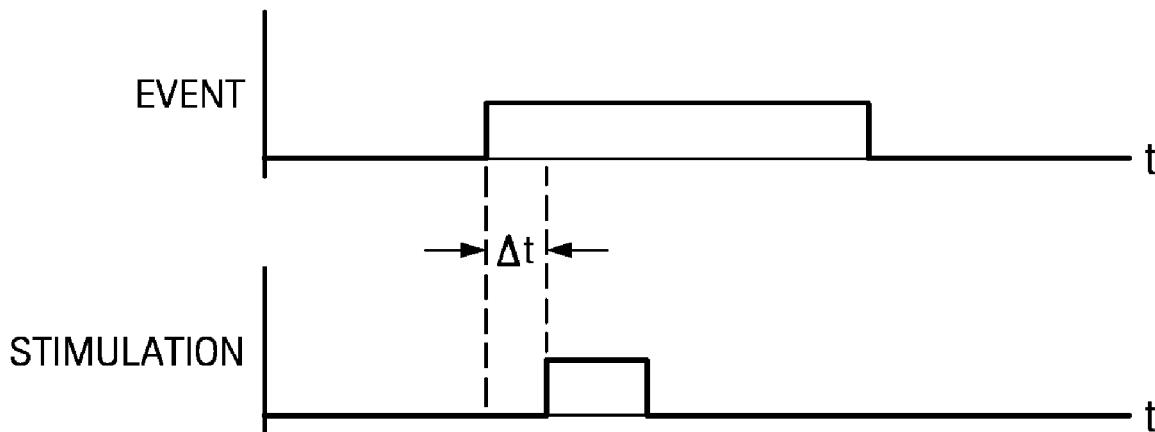

Related U.S. Application Data

- 12/485,857, filed on Jun. 16, 2009, now Pat. No. 8,489, 185, which is a continuation of application No. 12/485,040, filed on Jun. 15, 2009.
- (60) Provisional application No. 61/077,648, filed on Jul. 2, 2008, provisional application No. 61/086,116, filed on Aug. 4, 2008, provisional application No. 61/149,387, filed on Feb. 3, 2009.
- (51) **Int. Cl.**
G09B 23/28 (2006.01)
A61M 21/02 (2006.01)
H04R 25/00 (2006.01)
A61F 11/00 (2006.01)
A61M 21/00 (2006.01)
- (52) **U.S. Cl.**
 CPC **A61M 21/02** (2013.01); **A61N 1/361** (2013.01); **A61N 1/36014** (2013.01); **A61N 1/36053** (2013.01); **A61N 1/36067** (2013.01); **A61N 1/36092** (2013.01); **A61N 1/36103** (2013.01); **A61N 1/36139** (2013.01); **G09B 23/28** (2013.01); **H04R 25/75** (2013.01); **A61M 2021/0016** (2013.01); **A61M 2021/0022** (2013.01); **A61M 2021/0027** (2013.01); **A61M 2021/0044** (2013.01); **A61M 2021/0072** (2013.01); **A61M 2021/0077** (2013.01); **A61M 2205/3515** (2013.01); **A61M 2230/06** (2013.01); **A61M 2230/08** (2013.01); **A61M 2230/10** (2013.01); **A61M 2230/205** (2013.01); **A61M 2230/30** (2013.01); **A61M 2230/432** (2013.01); **A61M 2230/50** (2013.01); **A61M 2230/60** (2013.01); **A61M 2230/65** (2013.01); **A61N 1/36082** (2013.01)

5,324,316	A	6/1994	Schulman et al.
5,330,515	A	7/1994	Rutecki et al.
5,335,657	A	8/1994	Terry, Jr. et al.
5,363,858	A	11/1994	Farwell
5,405,367	A	4/1995	Schulman et al.
5,474,082	A	12/1995	Junker
5,559,507	A	9/1996	Beigel
5,571,148	A	11/1996	Loeb et al.
5,593,432	A	1/1997	Crowther et al.
5,662,689	A	9/1997	Elsberry et al.
5,735,887	A	4/1998	Barreras, Sr. et al.
5,741,316	A	4/1998	Chen et al.
5,755,747	A	5/1998	Daly et al.
5,776,170	A	7/1998	MacDonald et al.
5,779,665	A	7/1998	Mastrototaro et al.
5,782,874	A	7/1998	Loos
5,785,680	A	7/1998	Niezink et al.
5,800,458	A	9/1998	Wingrove
5,814,092	A	9/1998	King
5,833,603	A	11/1998	Kovacs et al.
5,833,714	A	11/1998	Loeb
5,871,512	A	2/1999	Hemming et al.
5,899,922	A	5/1999	Loos
5,913,882	A	6/1999	King
5,938,690	A	8/1999	Law et al.
5,945,938	A	8/1999	Chia et al.
5,954,758	A	9/1999	Peckham et al.
5,957,958	A	9/1999	Schulman et al.
5,970,398	A	10/1999	Tuttle
6,009,350	A	12/1999	Renken
6,051,017	A	4/2000	Loeb et al.
6,141,588	A	10/2000	Cox et al.
6,164,284	A	12/2000	Schulman et al.
6,175,764	B1	1/2001	Loeb et al.
6,181,965	B1	1/2001	Loeb et al.
6,181,969	B1	1/2001	Gord
6,185,452	B1	2/2001	Schulman et al.
6,185,455	B1	2/2001	Loeb et al.
6,201,980	B1	3/2001	Darrow et al.
6,208,894	B1	3/2001	Schulman et al.
6,208,902	B1	3/2001	Boveja
6,214,032	B1	4/2001	Loeb et al.
6,221,908	B1	4/2001	Kilgard et al.
6,240,316	B1	5/2001	Richmond et al.
6,263,247	B1	7/2001	Mueller et al.
6,270,472	B1	8/2001	Antaki et al.
6,308,102	B1	10/2001	Sieracki et al.
6,339,725	B1	1/2002	Naritoku et al. 607/45
6,345,202	B2	2/2002	Richmond et al.
6,354,989	B1	3/2002	Nudeshima
6,366,814	B1	4/2002	Boveja et al.
6,394,947	B1	5/2002	Leyseiffer
6,409,655	B1	6/2002	Wilson et al.
6,415,184	B1	7/2002	Ishikawa et al.
6,430,443	B1	8/2002	Karell
6,430,444	B1	8/2002	Borza
6,447,448	B1	9/2002	Ishikawa et al.
6,456,866	B1	9/2002	Tyler et al.
6,458,157	B1	10/2002	Suaning
6,463,328	B1	10/2002	John
6,480,730	B2	11/2002	Darrow et al.
6,505,075	B1	1/2003	Weiner
6,516,808	B2	2/2003	Schulman
6,546,290	B1	4/2003	Shloznikov
6,567,689	B2	5/2003	Burbank et al.
6,572,543	B1	6/2003	Christopherson et al.
6,582,441	B1	6/2003	He et al.
6,585,644	B2	7/2003	Lebel et al.
6,591,139	B2	7/2003	Lofin et al.
6,592,518	B2	7/2003	Denker et al.
6,626,676	B2	9/2003	Freer
6,650,943	B1	11/2003	Whitehurst et al.
6,658,297	B2	12/2003	Loeb
6,658,301	B2	12/2003	Loeb et al.
6,676,675	B2	1/2004	Mallapragada et al.
6,690,974	B2	2/2004	Archer et al.
6,695,885	B2	2/2004	Schulman et al.
6,712,753	B2	3/2004	Manne
6,721,603	B2	4/2004	Zabara et al.

(56) **References Cited**

U.S. PATENT DOCUMENTS

3,796,221	A	3/1974	Hagfors
3,830,242	A	8/1974	Greatbatch
3,885,211	A	5/1975	Gutai
3,893,462	A	7/1975	Manning
3,942,535	A	3/1976	Schulman
4,019,519	A	4/1977	Geerling
4,044,775	A	8/1977	McNichols
4,154,239	A	5/1979	Turley
4,167,179	A	9/1979	Kirsch
4,361,153	A	11/1982	Slocum et al.
4,399,818	A	8/1983	Money
4,541,432	A	9/1985	Molina-Negro et al.
4,592,359	A	6/1986	Galbraith
4,612,934	A	9/1986	Borkan
4,661,103	A	4/1987	Harman
4,723,536	A	2/1988	Rauscher et al.
4,750,499	A	6/1988	Hoffer
4,832,033	A	5/1989	Maher et al.
4,883,067	A	11/1989	Knispel et al.
4,902,987	A	2/1990	Albright
4,932,405	A	6/1990	Peeters et al.
4,977,895	A	12/1990	Tannenbaum
5,192,285	A	3/1993	Bolscher
5,193,539	A	3/1993	Schulman et al.
5,193,540	A	3/1993	Schulman et al.
5,222,494	A	6/1993	Baker, Jr.
5,234,316	A	8/1993	Rupprecht
5,250,026	A	10/1993	Ehrlich et al.
5,265,624	A	11/1993	Bowman
5,279,554	A	1/1994	Turley
5,288,291	A	2/1994	Teoh
5,299,569	A	4/1994	Wernicke et al. 607/45
5,312,439	A	5/1994	Loeb

(56)

References Cited

U.S. PATENT DOCUMENTS

6,731,979 B2	5/2004	MacDonald	7,406,105 B2	7/2008	DelMain et al.
6,733,485 B1	5/2004	Whitehurst et al.	7,437,195 B2	10/2008	Policker et al.
6,735,474 B1	5/2004	Loeb et al.	7,437,196 B2	10/2008	Wyler et al.
6,735,475 B1	5/2004	Whitehurst et al.	7,463,927 B1	12/2008	Chaouat
6,760,626 B1	7/2004	Boveja	7,481,771 B2	1/2009	Fonseca et al.
6,788,975 B1	9/2004	Whitehurst et al.	7,483,747 B2	1/2009	Gliner et al.
6,796,935 B1	9/2004	Savino	7,489,561 B2	2/2009	Armstrong et al.
6,804,561 B2	10/2004	Stover	7,489,966 B2	2/2009	Leinders et al.
6,829,508 B2	12/2004	Schulman et al.	7,493,172 B2	2/2009	Whitehurst et al.
6,832,114 B1	12/2004	Whitehurst et al.	7,526,341 B2	4/2009	Goetz et al.
6,836,685 B1	12/2004	Fitz	7,529,582 B1	5/2009	DiLorenzo
6,844,023 B2	1/2005	Schulman et al.	7,542,804 B2	6/2009	Mandell
6,845,267 B2	1/2005	Harrison et al.	7,547,353 B2	6/2009	Reyes et al.
6,855,115 B2	2/2005	Fonseca et al.	7,555,344 B2	6/2009	Maschino et al.
6,871,099 B1	3/2005	Whitehurst et al.	7,555,345 B2	6/2009	Wahlstrand et al.
6,885,888 B2	4/2005	Rezai	7,555,347 B2	6/2009	Loeb
6,895,279 B2	5/2005	Loeb et al.	7,558,631 B2	7/2009	Cowan et al.
6,895,280 B2	5/2005	Meadows et al.	7,563,279 B2	7/2009	Lasater
6,941,171 B2	9/2005	Mann et al.	7,565,199 B2	7/2009	Sheffield et al.
6,971,984 B2	12/2005	Ardizzone	7,565,200 B2	7/2009	Wyler et al.
6,974,437 B2	12/2005	Lebel et al.	7,577,481 B2	8/2009	Firlik et al.
6,990,377 B2	1/2006	Gliner et al. 607/54	7,590,454 B2	9/2009	Garabedian et al.
7,003,352 B1	2/2006	Whitehurst	7,593,776 B2	9/2009	Loeb et al.
7,006,870 B1	2/2006	Whitehurst et al.	7,596,413 B2	9/2009	Libbus et al.
7,006,875 B1	2/2006	Kuzma et al.	7,603,174 B2	10/2009	De Ridder
7,013,177 B1	3/2006	Whitehurst et al.	7,603,178 B2	10/2009	North et al.
7,024,247 B2	4/2006	Gliner et al.	7,613,519 B2	11/2009	DeRidder
7,027,860 B2	4/2006	Bruninga et al.	7,613,520 B2	11/2009	De Ridder
7,054,689 B1	5/2006	Whitehurst et al.	7,616,990 B2	11/2009	Chavan et al.
7,054,691 B1	5/2006	Kuzma et al.	7,630,771 B2	12/2009	Cauler
7,062,330 B1	6/2006	Boveja et al.	7,634,317 B2	12/2009	Ben-David et al.
7,076,307 B2	7/2006	Boveja et al.	7,636,603 B1	12/2009	Overstreet et al.
7,103,408 B2	9/2006	Haller et al.	7,715,915 B1	5/2010	Ryu et al.
7,107,103 B2	9/2006	Schulman et al.	7,765,013 B2	7/2010	Blick et al.
7,114,502 B2	10/2006	Schulman et al.	7,769,466 B2	8/2010	Denker et al.
7,117,034 B2	10/2006	Kronberg	7,786,867 B2	8/2010	Hamel et al.
7,132,173 B2	11/2006	Daulton	7,801,615 B2	9/2010	Meadows et al.
7,146,217 B2	12/2006	Firlik et al.	7,822,480 B2	10/2010	Park et al.
7,147,604 B1	12/2006	Allen et al.	2001/0016683 A1	8/2001	Darrow et al.
7,149,574 B2	12/2006	Yun et al.	2002/0022872 A1	2/2002	Gielen et al.
7,155,279 B2	12/2006	Whitehurst et al.	2002/0029005 A1	3/2002	Levendowski et al.
7,174,215 B2	2/2007	Bradley	2002/0051806 A1	5/2002	Mallapragada et al.
7,184,837 B2	2/2007	Goetz	2002/0058853 A1	5/2002	Kaplan
7,187,968 B2	3/2007	Wolf et al.	2002/0077672 A1	6/2002	Govari et al.
7,191,012 B2	3/2007	Boveja et al.	2002/0193845 A1	12/2002	Greenberg et al.
7,194,007 B1	3/2007	Beadle et al.	2003/0004411 A1	1/2003	Govari et al.
7,209,787 B2	4/2007	DiLorenzo	2003/0013948 A1	1/2003	Russell
7,209,788 B2	4/2007	Nicolelis et al.	2003/0014091 A1	1/2003	Rastegar et al.
7,209,792 B1	4/2007	Parramon et al.	2003/0114899 A1	6/2003	Woods et al.
7,211,048 B1	5/2007	Najafi et al.	2003/0139677 A1	7/2003	Fonseca et al.
7,212,110 B1	5/2007	Martin et al.	2003/0139783 A1	7/2003	Kilgore et al.
7,212,866 B1	5/2007	Griffith	2003/0144709 A1	7/2003	Zabara et al.
7,221,981 B2	5/2007	Gliner	2003/0171758 A1	9/2003	Gibson et al.
7,231,256 B2	6/2007	Wahlstrand et al.	2003/0225331 A1	12/2003	Diederich et al.
7,236,822 B2	6/2007	Dobak, III	2004/0031065 A1	2/2004	Barth
7,236,830 B2	6/2007	Gliner	2004/0172075 A1	9/2004	Shafer et al.
7,236,831 B2	6/2007	Firlik et al.	2004/0172083 A1	9/2004	Penner
7,256,695 B2	8/2007	Hamel et al.	2004/0176831 A1	9/2004	Gliner et al.
7,290,890 B2	11/2007	Yoshida et al.	2004/0181261 A1	9/2004	Manne
7,292,890 B2	11/2007	Whitehurst et al.	2004/0253209 A1	12/2004	Soykan et al.
7,299,096 B2	11/2007	Balzer et al.	2004/0267152 A1	12/2004	Pineda
7,302,298 B2	11/2007	Lowry et al.	2005/0015014 A1	1/2005	Fonseca et al.
7,305,268 B2	12/2007	Gliner et al.	2005/0021100 A1	1/2005	Tsukamoto et al.
7,324,852 B2	1/2008	Barolat et al.	2005/0070974 A1	3/2005	Knudson et al.
7,328,069 B2	2/2008	Gerber	2005/0131386 A1	6/2005	Freeman et al.
7,330,756 B2	2/2008	Marnfeldt	2005/0137652 A1	6/2005	Cauler et al.
7,337,004 B2	2/2008	Classen et al.	2005/0143789 A1	6/2005	Whitehurst et al.
7,353,064 B2	4/2008	Gliner et al.	2005/0209667 A1	9/2005	Erickson et al.
7,359,751 B1	4/2008	Erickson et al.	2005/0222641 A1	10/2005	Pless
7,361,135 B2	4/2008	Drobnik et al.	2005/0245989 A1	11/2005	Davis
7,369,897 B2	5/2008	Boveja et al.	2005/0256551 A1	11/2005	Schulman et al.
7,373,204 B2	5/2008	Gelfand et al.	2005/0258242 A1	11/2005	Zarembo
7,384,403 B2	6/2008	Sherman	2006/0058570 A1	3/2006	Rapach et al.
7,386,348 B2	6/2008	North et al.	2006/0079936 A1	4/2006	Boveja et al. 607/2
7,389,145 B2	6/2008	Kilgore et al.	2006/0173263 A1	8/2006	He et al.
			2006/0173493 A1	8/2006	Armstrong et al.
			2006/0195154 A1	8/2006	Jaax et al.
			2006/0206149 A1	9/2006	Yun
			2006/0224214 A1	10/2006	Koller et al.

(56)

References Cited

U.S. PATENT DOCUMENTS

2006/0241354 A1 10/2006 Allen
 2006/0247719 A1 11/2006 Maschino et al.
 2006/0271110 A1 11/2006 Vernon et al.
 2007/0010809 A1 1/2007 Hovda et al.
 2007/0021786 A1 1/2007 Parnis et al.
 2007/0027486 A1 2/2007 Armstrong
 2007/0027504 A1 2/2007 Barrett et al.
 2007/0032734 A1 2/2007 Najafi et al.
 2007/0077265 A1 4/2007 Klueh et al.
 2007/0123938 A1 5/2007 Haller et al.
 2007/0179534 A1 8/2007 Firlirk et al.
 2007/0191908 A1 8/2007 Jacob et al.
 2007/0225767 A1 9/2007 Daly et al.
 2007/0265172 A1 11/2007 Patel et al.
 2007/0265683 A1 11/2007 Ehrlich
 2007/0275035 A1 11/2007 Herman et al.
 2007/0293908 A1 12/2007 Cowan et al.
 2008/0033351 A1 2/2008 Trogden et al.
 2008/0033502 A1 2/2008 Harris et al.
 2008/0058892 A1 3/2008 Haefner et al.
 2008/0065182 A1 3/2008 Strother et al.
 2008/0084898 A1 4/2008 Miyaho et al.
 2008/0084911 A1 4/2008 Yerlikaya
 2008/0084941 A1 4/2008 Mohanty et al.
 2008/0084951 A1 4/2008 Chen et al.
 2008/0084972 A1 4/2008 Burke et al.
 2008/0084986 A1 4/2008 Kumarasamy et al.
 2008/0103548 A1 5/2008 Fowler et al.
 2008/0109046 A1 5/2008 Lima et al.
 2008/0243204 A1 10/2008 Uthman et al.
 2008/0259681 A1 10/2008 Branch et al.
 2008/0275369 A1 11/2008 Fandriks
 2008/0281210 A1 11/2008 Nunez et al.
 2008/0281212 A1 11/2008 Nunez et al.
 2008/0281368 A1 11/2008 Bulkes et al.
 2008/0319506 A1 12/2008 Cauller
 2009/0015331 A1 1/2009 Segarra
 2009/0024042 A1 1/2009 Nunez et al.
 2009/0024189 A1 1/2009 Lee et al.
 2009/0030476 A1 1/2009 Hargrove
 2009/0049321 A1 2/2009 Balatsos et al.
 2009/0132003 A1 5/2009 Borgens et al.
 2009/0149918 A1 6/2009 Krulevitch et al.
 2009/0157142 A1 6/2009 Cauller
 2009/0157145 A1 6/2009 Cauller
 2009/0157147 A1 6/2009 Cauller et al.
 2009/0157150 A1 6/2009 Cauller
 2009/0157151 A1 6/2009 Cauller et al.
 2009/0163889 A1 6/2009 Cauller et al.
 2009/0198293 A1 8/2009 Cauller et al.
 2009/0209804 A1 8/2009 Seiler et al.
 2009/0216115 A1 8/2009 Seiler et al.
 2009/0247939 A1 10/2009 Rue et al.
 2009/0264813 A1 10/2009 Chang
 2009/0292325 A1 11/2009 Cederna et al.
 2009/0312594 A1 12/2009 Lamoureux et al.
 2010/0003656 A1 1/2010 Kilgard et al.
 2010/0004705 A1 1/2010 Kilgard et al.
 2010/0022908 A1 1/2010 Cauller
 2010/0036211 A1 2/2010 La Rue et al.
 2010/0036445 A1 2/2010 Sakai et al.
 2010/0057160 A1 3/2010 De Ridder
 2010/0063564 A1 3/2010 Libbus et al.
 2010/0069992 A1 3/2010 Aghassian et al.
 2010/0069994 A1 3/2010 Cauller
 2010/0100010 A1 4/2010 Andarawis et al.
 2010/0100079 A1 4/2010 Berkcan et al.
 2010/0106217 A1 4/2010 Colborn
 2010/0125314 A1 5/2010 Bradley et al.
 2010/0137961 A1 6/2010 Moffitt et al.
 2010/0145216 A1 6/2010 He et al.
 2010/0145401 A1 6/2010 Pastore et al.
 2010/0174341 A1 7/2010 Bolea et al.

2010/0222844 A1 9/2010 Troosters et al.
 2010/0331921 A1 12/2010 Bomzin et al.
 2011/0004266 A1 1/2011 Sharma

FOREIGN PATENT DOCUMENTS

DE 2004050616 B3 3/2006
 DE 112008001669 T5 5/2010
 DE 11208003192 T5 10/2010
 DE 11208003194 T5 2/2011
 DE 11208003180 T5 3/2011
 EP 0247649 A1 2/1987
 EP 1575665 A1 9/2005
 EP 1719540 A3 8/2006
 EP 1785160 A2 5/2007
 WO 96/19257 A1 6/1996
 WO 98/17628 A2 4/1998
 WO 98/43701 A1 10/1998
 WO 02/082982 A1 10/2002
 WO 03/003791 A1 1/2003
 WO 03/015863 A2 2/2003
 WO 03/018113 A1 3/2003
 WO 03/076010 A1 9/2003
 WO 2004060144 A2 7/2004
 WO 2005061045 A1 7/2005
 WO 2005067792 A1 7/2005
 WO 2006020377 A2 2/2006
 WO 2006029007 A2 3/2006
 WO 2006029257 A2 3/2006
 WO 2006091611 A1 8/2006
 WO 2007073557 A2 6/2007
 WO 2007098202 A3 8/2007
 WO 2007106692 A2 9/2007
 WO 2007136657 A2 11/2007
 WO 2007146213 A2 12/2007
 WO 2008103977 A2 8/2008
 WO 2008133797 A1 11/2008
 WO 2008150348 A1 12/2008
 WO 2008151059 A2 12/2008
 WO 2009018172 A2 2/2009
 WO 2009035515 A1 3/2009
 WO 2009070697 A2 6/2009
 WO 2009070705 A2 6/2009
 WO 2009070709 A1 6/2009
 WO 2009070715 A2 6/2009
 WO 2009070719 A1 6/2009
 WO 2009070738 A1 6/2009
 WO 2009110935 A1 9/2009
 WO 2009111012 A1 9/2009
 WO 2009015104 A2 12/2009
 WO 2010002936 A2 1/2010
 WO 2010022071 A2 2/2010
 WO 2010124321 A1 11/2010

OTHER PUBLICATIONS

Schwiebert, L. et al., "Research Challenges in Wireless Networks of Biomedical Sensors," Disclosing for maximizing signal distance/minimizing power with multiple implant arrays in section 5.1, pp. 159-161, 2001.
 Shabou, S. et al., "The RF Circuit Design for Magnetic Power Transmission Dedicated to Cochlear Prosthesis," 12th IEEE International Conference on Electronics, Circuits and Systems, 2005, pp. 1-4, Abstract.
 Sharma, N. et al., "Electrical Stimulation and Testosterone Differentially Enhance Expression of Regeneration-Associated Genes," *Exp Neurol.*, vol. 1, May 2010, pp. 183-191, Abstract.
 Shepherd, RD et al., "Electrical Stimulation of the Auditory Nerve: II. Effect of Stimulus Waveshape on Single Fibre Response Properties," *Hear Res.*, vol. 130, Apr. 1999, pp. 171-188, Abstract.
 Sit, Ji-Jon et al., "A Low-Power Blocking-Capacitor-Free Charge-Balanced Electrode-Stimulator Chip with Less Than 6 nA DC Error for 1-mA Full-Scale Stimulation," *IEEE Transactions on Biomedical Circuits and Systems*, vol. 1, No. 3, Sep. 2007, pp. 172-183.
 Sooksood, K., et al., "Recent Advances in Charge Balancing for Functional Electrical Stimulation", *Conf. Proc. IEEE Eng. Med. Biol. Soc.*, Nov. 13, 2009, Abstract.

(56)

References Cited

OTHER PUBLICATIONS

- Mouine, J. et al., "A Completely Programmable and Very Flexible Implantable Pain Controller," Proc. of the 22nd Annual Intern Conference of the IEEE, vol. 2, 2000, pp. 1104-1107, Abstract.
- Mounaim, F. et al., "Miniature Implantable System Dedicated to Bi-Channel Selective Neurostimulation," IEEE International Symposium on Circuits and Systems, 2007, pp. 2072-2075, Abstract.
- Myers, F.B. et al., "A Wideband Wireless Neural Stimulation Platform for High-Density Microelectrode Arrays," 28th Annual International Conference of the IEEE Engineering in Medicine and Biology Society, Aug. 30, 2006, pp. 4404-4407, Abstract.
- Papazoglou, C. et al., "Endoluminal Grafting: The Arizona Heart Institute Experience," International Congress VIII on Endovascular Interventions, Breaking Barriers, Scottsdale, Arizona, Feb. 12-16, 1995, pp. 89-129.
- Peters, T.K. et al., "The Evolution Strategy—A Search Strategy Used in Individual Optimization of Electrica Therapeutic Carotid Sinus Nerve Stimulation," IEEE Transactions on Biomedical Engineering, vol. 36, Issue 7, pp. 668-675, Abstract <http://ieeexplore.ieee.org/search/srchabstract.jsp?tp=&arnumber=32098&query-Text%3D%28Implant+And+induction%29+AND+%28antenna+OR+coil%29+AND+%28t%29%26searchWit>, Abstract, 1989.
- Popovic, D.B. et al., "Electrical Stimulation as a Means for Achieving Recovery of Function in Stoke Patients," NeuroRehabilitation, vol. 1, 2009, pp. 45-58. Abstract <http://www.ncbi.nlm.nih.gov/pubmed/19713618>.
- Sawan, M., "Medical Microsystems for the Recovery of Vital Neural Functions," ncku.edu.tw polystim neurotechnologies Tianan, Taiwan, http://www.google.com/url?sa=t&source=web&cd=1&ved=0CBcQFjAA&url=http%3A%2F%2Ford.ncku.edu.tw%2Ffezfiles%2F3%2F1003%2Fimg%2F467%2F20080911_ppt.pdei=clayTZeNO-Ls0ghW71HCcw&usq=AFQjCNE8HVhol0Y63ztvd1sxK8-8aDdLAW&sig2=c7qWnlzQ2QUrwRMDvC53Gw
- Bohotin, C., Scholsem, M., Bohotin, V., Franzen, R. and Schoenen, J., "Vagus Nerve Stimulation Attenuates Hear-and Formalin-Induced Pain in Rats", Neuroscience Letters, 2003, vol. 351, pp. 79-82.
- Bohotin, C., Scholsem, M., Multon, S., Martin, D., Bohotin, V., Schoenen, J., Vagus Nerve Stimulation in Awake Rats Reduces Formalin-Induced Nociceptive Behavior and Fos-Immunoreactivity in Trigeminal Nucleus Caudalis, Pain 101, 2003, pp. 3-12.
- Burridge, J. and Etherington, R., "A Preliminary Clinical Study using RF BION Microstimulators to Facilitate Upper Limb Function in Hemiplegia", Advances in Clinical Neurosciences and Rehabilitation, May/June. 2004, vol. 4, pp. 26-27.
- Caulier, L. and Lee, J., "In Vivo Tests of Switched-Capacitor Neural Stimulation for Use in Minimally-Invasive Wireless Implants", IEEE International Symposium on Circuits and Systems, 2008, 2 pages.
- Chuang, H., "Numerical Computation of Fat Layer Effects on Microwave Near-Field Radiation to the Abdomen of a Full-Scale Human Body Model", IEEE Transactions on Microwave Theory and Techniques, vol. 45, Jan. 1997, pp. 118-125.
- Cogan, S., "Neural Stimulation and Recording Electrodes" Annual Review of Biomedical Engineering, vol. 1, 2008, pp. 275-309.
- Ghovanloo, M., "A Switched-Capacitor Based Neurostimulating System for Low-Power Wireless Microstimulating Systems", IEEE International Symposium on Circuits and Systems, May 2006, pp. 2197-2200.
- Gopalkrishnan, P. and Sluka, K., "Effect of Varying Frequency, Intensity, and Pulse Duration of Transcutaneous Electrical Nerve Stimulation on Primary Hyperalgesia in Inflamed Rats", The American Congress of Rehabilitation Medicine and the American Academy of Physical Medicine and Rehabilitation, vol. 81, Jul. 2000, pp. 984-990.
- Goroszeniuk, T., Kothari, S. and Hamann, W., "Subcutaneous Neuromodulating Implant Targeted at the Site of Pain", Regional Anesthesia and Pain Medicine, vol. 31, No. 2, Mar./Apr. 2006, pp. 168-171.
- Huang et al., "A 0.5-mW Passive Telemetry IC for Biomedical Applications", IEEE Journal of Solid-State Circuits, vol. 33, No. 7, Jul. 1998, pp. 937-946.
- Kilgore, K., Bhadra, N. and Snyder, J., "Treatment of Neuroma Pain Using High Frequency Alternating Current" poster, 1 page.
- Li, C., and Bak, A., "Excitability Characteristics of the A- and C-Fibers in a Peripheral Nerve", Experimental Neurology, vol. 50, 1976, pp. 67-79.
- Mendlin, A., Martin F.J., A. and Jacobs, B., "Dopaminergic Input is Required for Increases in Serotonin Output Produced by Behavioral Activation: An in Vivo Microdialysis Study in Rat Forebrain", Neuroscience, vol. 93, No. 3, 1999, pp. 897-905.
- Millard, R. and Shepherd, R., "A Fully Implantable Stimulator for use in Small Laboratory Animals", Journal of Neuroscience Methods, 2007, pp. 168-177.
- Mokwa et al., "Micro-Transponder Systems for Medical Applications", IEEE Transactions on Instrumentation and Measurement, vol. 50, No. 6, Dec. 2001, pp. 1551-1555.
- Nair, S.G. and Gudelsky, G.A., "Effect of a Serotonin Depleting Regimen of 3, 4-Methylenedioxymethamphetamine (MDMA) on the Subsequent Stimulation of Acetylcholine Release in the Rat Prefrontal Cortex", Elsevier Brain Research Bulletin 69, Jan. 23, 2006, pp. 382-387.
- Parikh, V., Pomerleau, F., Huettl, P., Gerhardt, G., Sarter, M. and Bruno, J.P., "Rapid Assessment of in Vivo Cholinergic Transmission by Amperometric Detection of Changes in Extracellular Choline Levels", European Journal of Neuroscience, vol. 20, Jul. 12, 2004, pp. 1545-1554.
- Rainov, N., Fels, C., Heidecke, V. and Burkert, W., "Epidural Electrical Stimulation of the Motor Cortex in Patients with Facial Neuralgia", Clinical Neurology and Neurosurgery 99, 1997, pp. 205-209.
- Saito, Y., Matida, S., Anami, S. Baba, H., Kinbara, A., Horikoshi, G., and Tanaka, J., "Breakdown of Alumina RF Windows", American Institute of Physics, Rev. Sci. Instrum., vol. 60, No. 7, Jul. 1989, pp. 1736-1740.
- Sakai, Y., Nishijima, Y., Mikuni, N. and Iwata, N., "An Experimental Model of Hyper-Irritability in the Trigeminal Skin Field of the Rat", Pain, vol. 7, 1979, pp. 147-157.
- Sandkuhler, J., Chen, J., Cheng, G. and Randic, M., "Low-Frequency Stimulation of Afferent Aδ-Fibers Induces Long-Term Depression at Primary Afferent Synapses with Substantia Gelatinosa Neurons in the Rat", The Journal of Neuroscience, vol. 17, Issue 16, Aug. 15, 1997, pp. 6473-6491.
- Sandkuhler, J., "Understanding LTP in Pain Pathways", Molecular Pain, vol. 3, Issue 9, Apr. 3, 2007, pp. 1-9.
- Sheng, L., Nishiyama, K., Honda, T., Sugiura, M., Yaginuma, H. and Sugiura, Y., "Suppressive Affects of Neiting Acupuncture on Toothache: An Experimental Analysis on Fos Expression Evoked by Tooth Pulp Stimulation in the Trigeminal Subnucleus Pars Caudalis and the Periaqueductal Gray of Rats", Neuroscience Research, vol. 38, 2000, pp. 331-339.
- Simpson, J. and Ghovanloo, M., "An Experimental Study of Voltage, Current, and Charge Controlled Stimulation Front-End Circuitry", IEEE International Symposium on Circuits and Systems, May 2007, pp. 325-328.
- Simpson, J., Krishnamurthy, G., Feller, G., Murrow, R., and Ghovanloo, M., "A Switched-Capacitor Based Neurostimulating System for Low-Power Head-Mounted Deep Brain Stimulators", NCBIIONICS, North Carolina State University, 1 page.
- Spinner, R., "Outcomes for Peripheral Entrapment Syndromes", Clinical Neurosurgery, vol. 53, 2006, pp. 285-294.
- Tsodyks, M., "Computational neuroscience grand challenges—a humble attempt at future forecast", Frontiers in Neuroscience, vol. 2, Jul. 2008, pp. 17-18.
- Vuckovic, A. and Rijkhoff, N., "Different Pulse Shapes for Selective Large Fibre Block in Sacral Nerve Roots Using a Technique of Anodal Block: An experimental Study" Medical & Biological Engineering & Computing, vol. 42, 2004, pp. 817-824.
- Wever, R. and Hemrika, W., "Vanadium Haloperoxidases", Handbook of Metalloproteins, John Wiley & Sons, Ltd. Chichester, 2001, pp. 1416-1428.
- EZstim II Peripheral Nerve Locator and Stimulator, Model ES400, Operator's Manual, Life-Tech, Inc., 2005, 29 pages.

(56)

References Cited

OTHER PUBLICATIONS

- “Multi-Program Neurostimulator”, Implant Manual, Medtronic, 2006, 16 pages.
- “Stimuplex Nerve Stimulator” brochure, Braun, 4 pages.
- Office Action dated Aug. 19, 2010, 8 pages, U.S. Appl. No. 12/323,854, filed Nov. 26, 2008.
- Office Action dated Dec. 22, 2010, 11 pages, U.S. Appl. No. 12/323,904, filed Nov. 26, 2008.
- Office Action dated Dec. 2, 2010, 9 pages, U.S. Appl. No. 12/323,934, filed Nov. 26, 2008.
- Office Action dated Oct. 4, 2010, 11 pages, U.S. Appl. No. 12/323,952, filed Nov. 26, 2008.
- Office Action dated Jul. 9, 2010, 18 pages, U.S. Appl. No. 12/323,952, filed Nov. 26, 2008.
- Office Action dated Jan. 19, 2011, 11 pages, U.S. Appl. No. 12/323,969, filed Nov. 26, 2008.
- Office Action dated Aug. 30, 2010, 5 pages, U.S. Appl. No. 12/323,969, filed Nov. 26, 2008.
- Office Action dated Dec. 9, 2010, 7 pages, U.S. Appl. No. 12/324,000, filed Nov. 26, 2008.
- Engineer, et al., “Reversing Pathological Neural Activity Using Targeted Plasticity,” *Nature*, vol. 47, Feb. 3, 2011, pp. 101-106.
- Kipke, D., Vetter, R., Williams, J., and Hetke, J., “Silicon-Substrate Intracortical Microelectrode Arrays for Long-Term Recording of Neuronal Spike Activity in Cerebral Cortex”, *IEEE Transactions on Neural Systems and Rehabilitation Engineering*, vol. 11, No. 2, Jun. 2003, pp. 151-155.
- Vetter, R., et al., “Chronic Neural Recording Using Silicon-Substrate Microelectrode Arrays Implanted in Cerebral Cortex”, *IEEE Transactions on Biomedical Engineering*, vol. 51, No. 6, Jun. 2004, pp. 896-904.
- Foreign Communication From a Related Counterpart Application—International Search Report, PCT/US2008/068165, dated Dec. 24, 2008, 3 pages.
- Foreign Communication From a Related Counterpart Application—International Search Report, PCT/US2008/084898, dated May 26, 2009, 6 pages.
- Foreign Communication From a Related Counterpart Application—Written Opinion PCT/US2008/084898, dated May 26, 2009, 5 pages.
- Foreign Communication From a Related Counterpart Application—International Search Report, PCT/US2009/049321, dated Feb. 9, 2010, 8 pages.
- Foreign Communication From a Related Counterpart Application—Written Opinion, PCT/US2009/049321, dated Feb. 9, 2010, 4 pages.
- Foreign Communication From a Related Counterpart Application—Office Action dated Jul. 6, 2010, Australian Application No. 2008329642, 2 pages.
- Foreign Communication From a Related Counterpart Application—Office Action dated Jul. 6, 2010, Australian Application No. 2008329648, 2 pages.
- Foreign Communication From a Related Counterpart Application—Office Action dated Jul. 6, 2010, Australian Application No. 2008329652, 2 pages.
- Foreign Communication From a Related Counterpart Application—Office Action dated Jul. 6, 2010, Australian Application No. 2008329671, 2 pages.
- Foreign Communication From a Related Counterpart Application—Office Action dated Jul. 6, 2010, Australian Application No. 2008329716, 2 pages.
- Foreign Communication From a Related Counterpart Application—Office Action dated Jul. 6, 2010, Australian Application No. 2008329724, 2 pages.
- Foreign Communication From a Related Counterpart Application—Office Action dated Jul. 6, 2010, Australian Application No. 2008352005, 2 pages.
- Office Action dated Feb. 24, 2011, 7 pages, U.S. Appl. No. 12/323,854, filed Nov. 26, 2008.
- Cauler, Lawrence J.; U.S. Appl. No. 12/611,105; Title: “Short-Pulse Neural Stimulation Systems, Devices and Methods”, filed Nov. 18, 2009; Specification 10 pgs.; 3 Drawing Sheets (Figs. 1-7).
- Cauler, Lawrence J.; U.S. Appl. No. 12/611,110; Title: “Parasthesia Using Short-Pulse Neural Stimulation Systems, Devices and Methods”, filed Nov. 2, 2009; Specification 10 pages; 3 Drawing Sheets (Figs. 1-7).
- Office Action dated Mar. 10, 2011, 10 pages, U.S. Appl. No. 12/485,040, filed Jun. 15, 2009.
- Foreign Communication from a Related Counterpart Application—Office Action dated Apr. 13, 2011, German Application No. 112008003184.3.
- Office Action dated Apr. 19, 2011, 8 pages, U.S. Appl. No. 12/323,952, filed Nov. 26, 2008.
- Office Action dated Apr. 28, 2011, 8 pages, U.S. Appl. No. 12/324,000, filed Nov. 26, 2008.
- Office Action dated May 5, 2011, 8 pages, U.S. Appl. No. 12/485,860, filed Jun. 16, 2009.

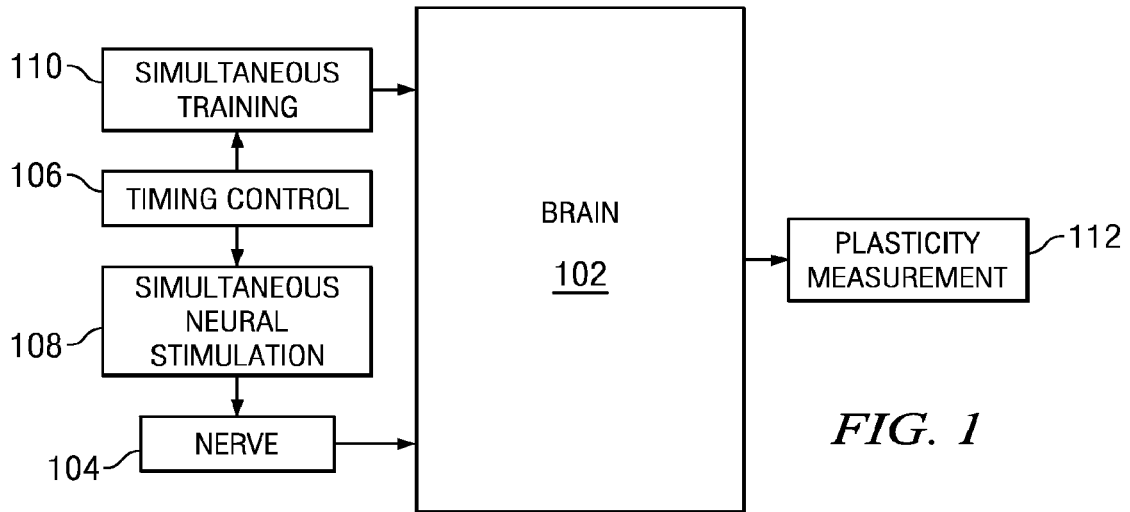

FIG. 1

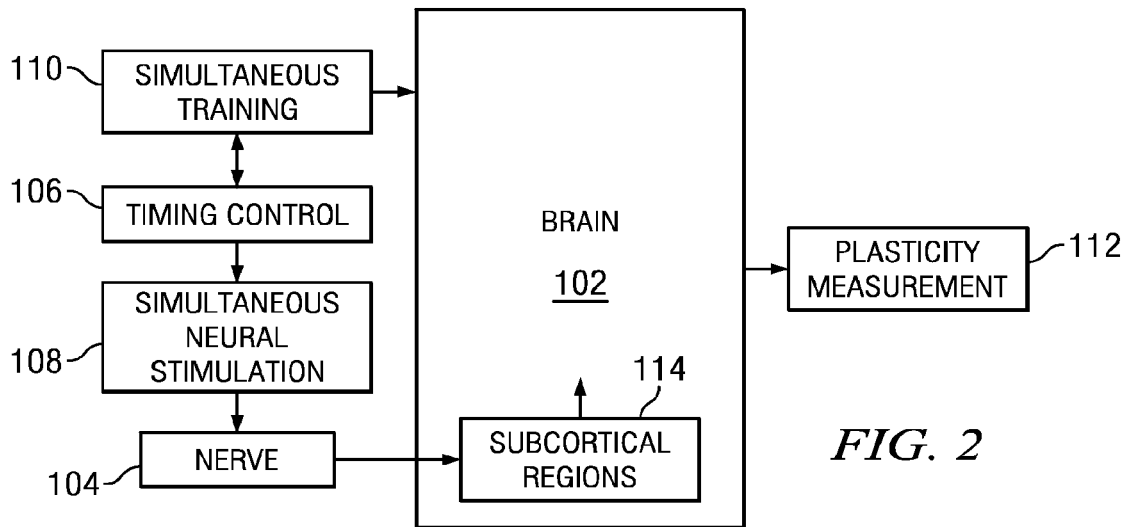

FIG. 2

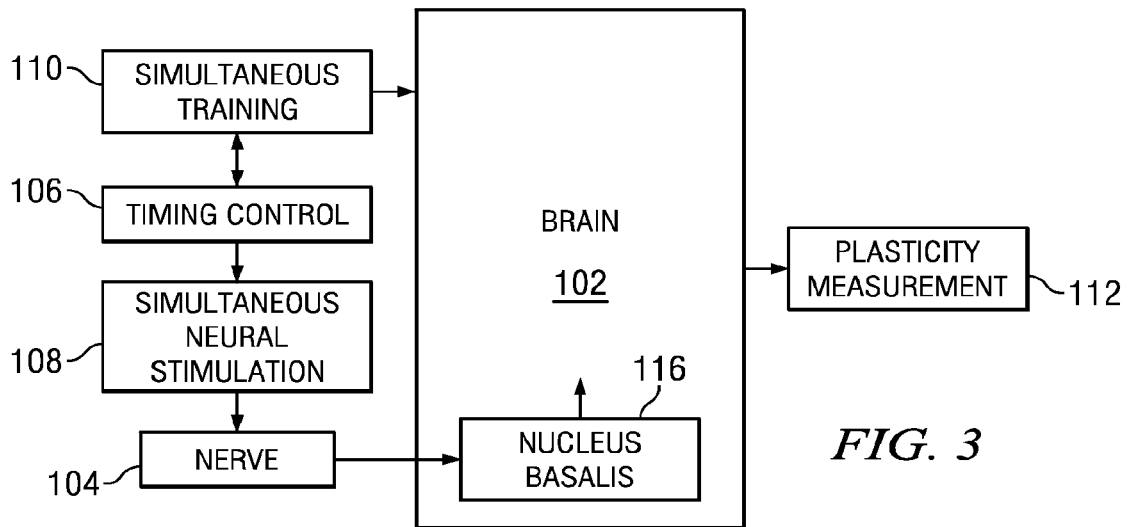

FIG. 3

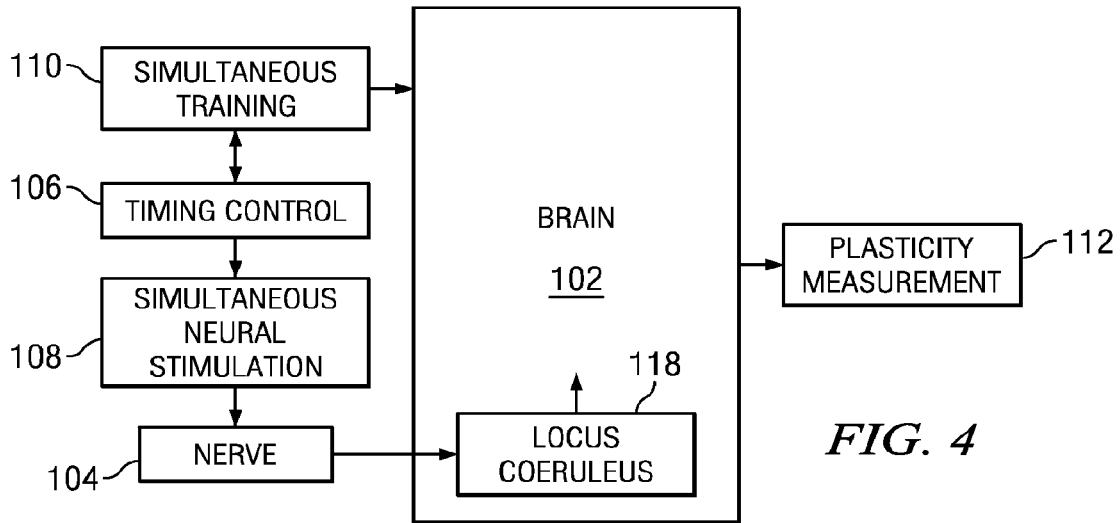

FIG. 4

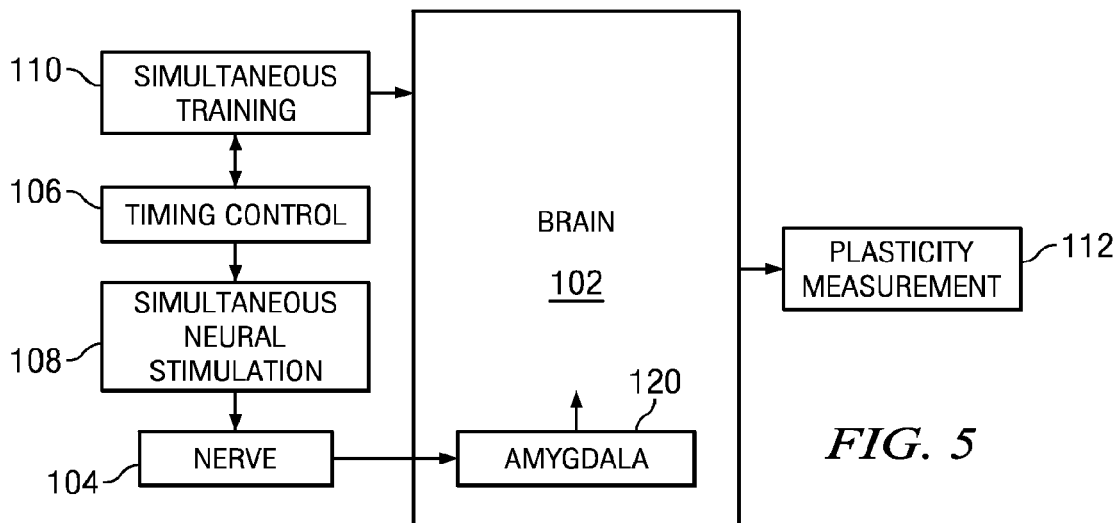

FIG. 5

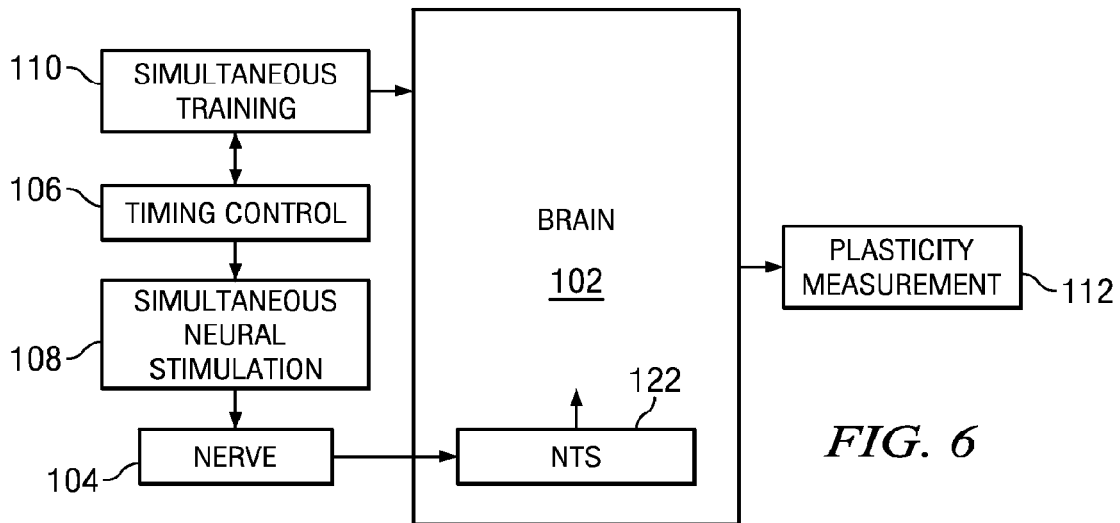

FIG. 6

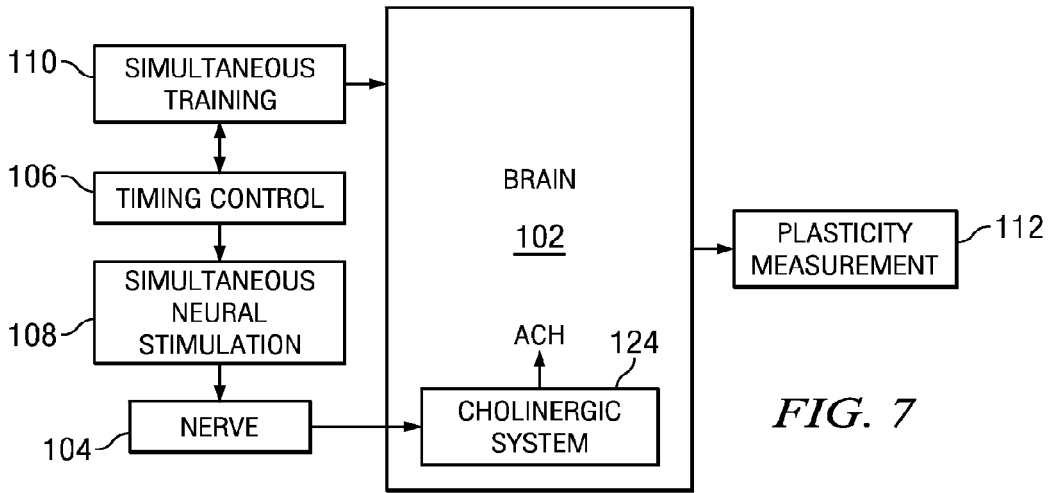

FIG. 7

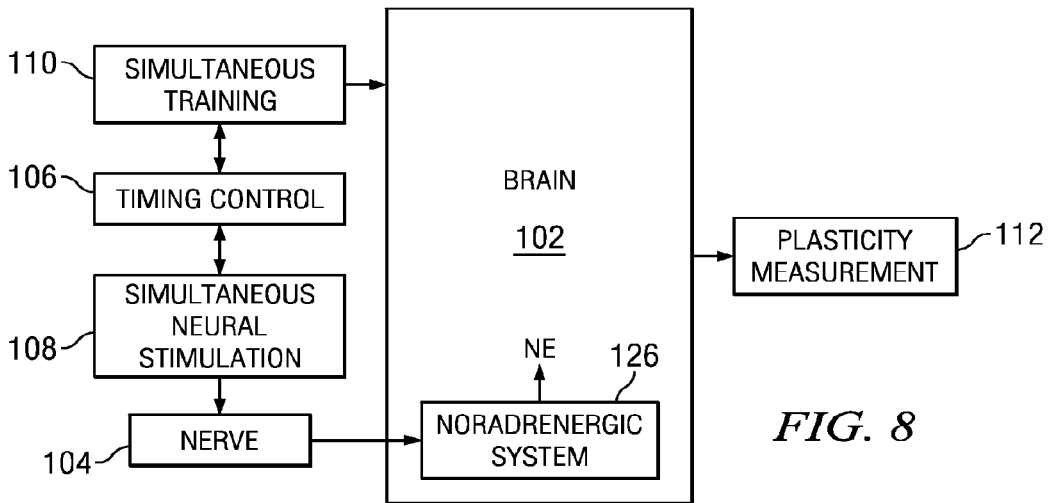

FIG. 8

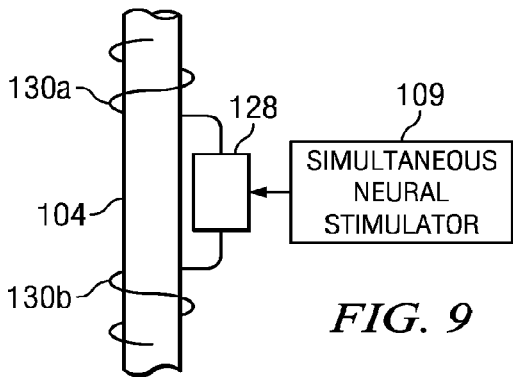

FIG. 9

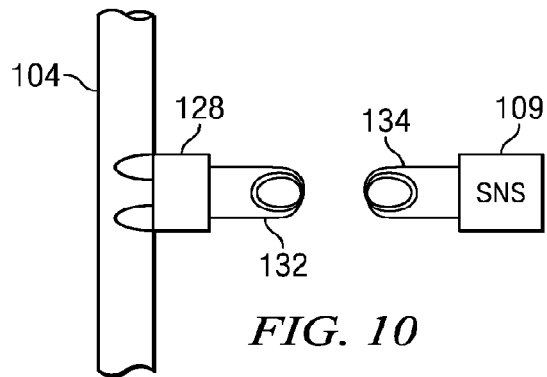
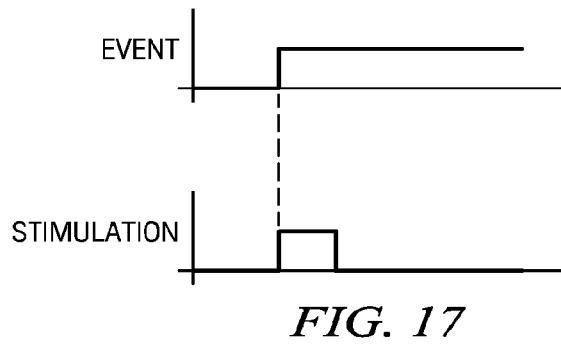
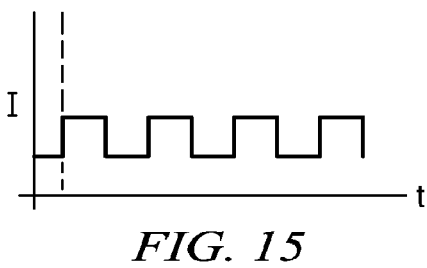
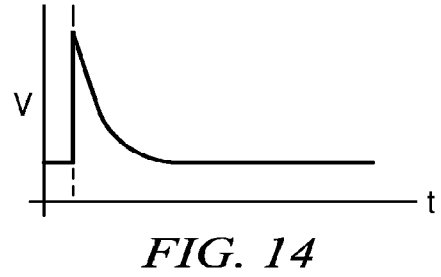
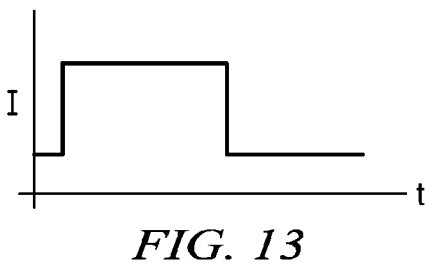
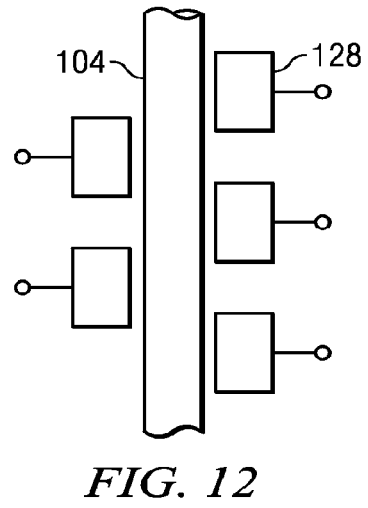
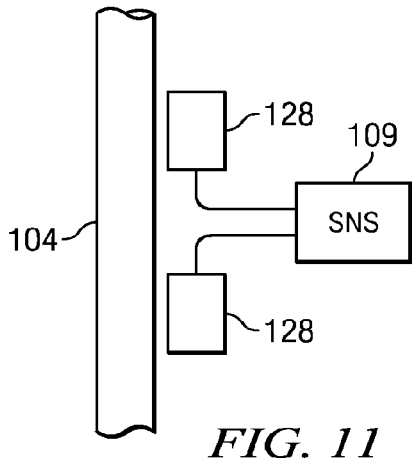

FIG. 10



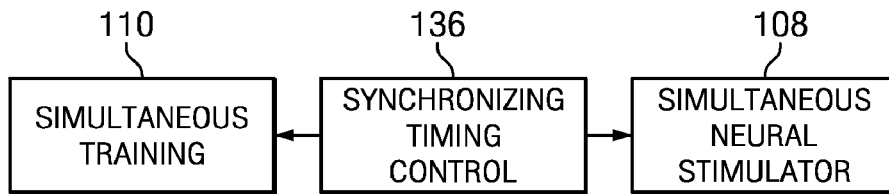

FIG. 16

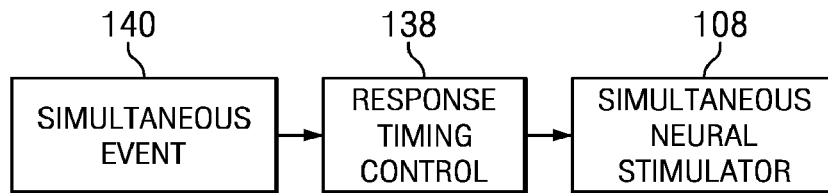

FIG. 18

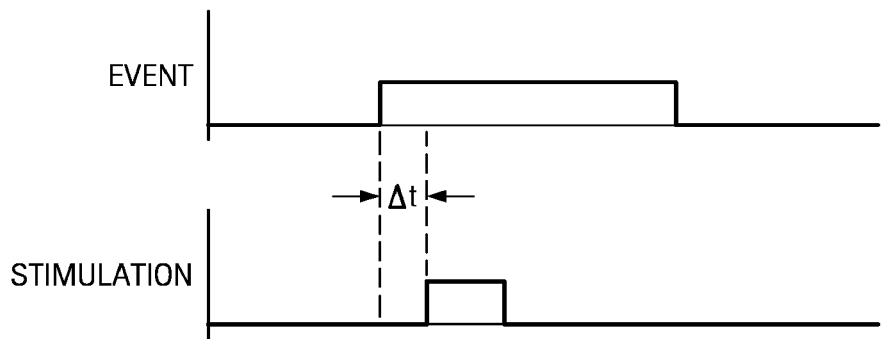

FIG. 19

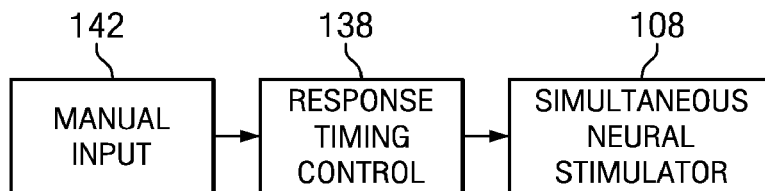

FIG. 20

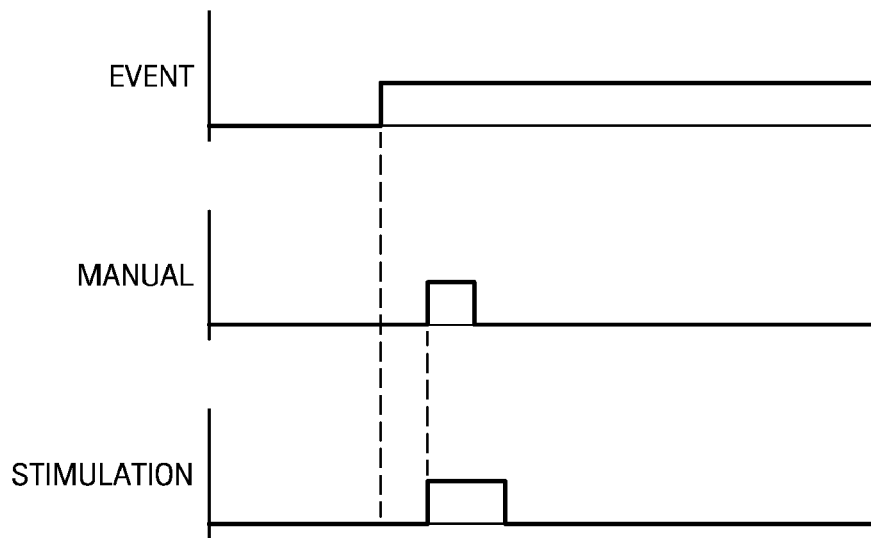

FIG. 21

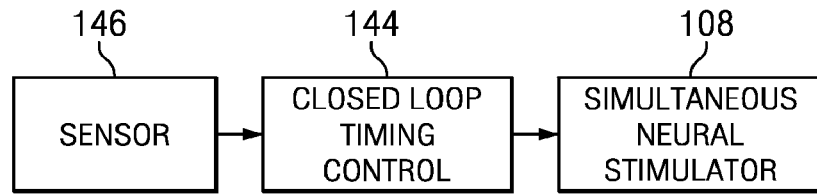

FIG. 22

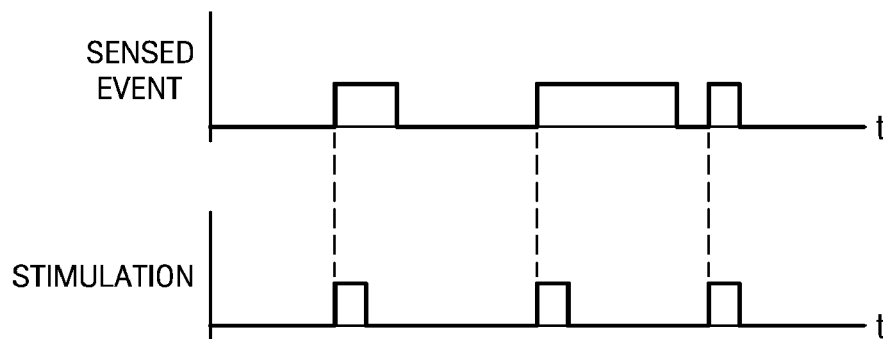

FIG. 23

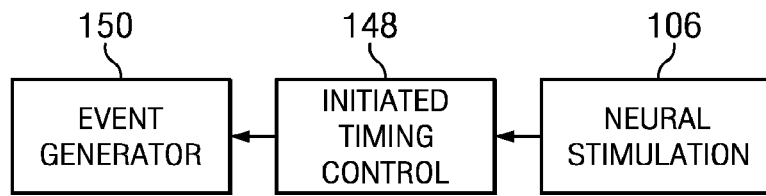

FIG. 24

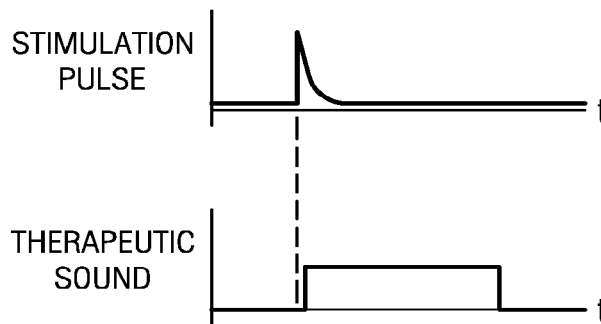

FIG. 25

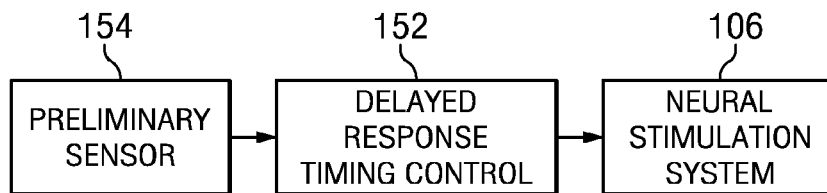

FIG. 26

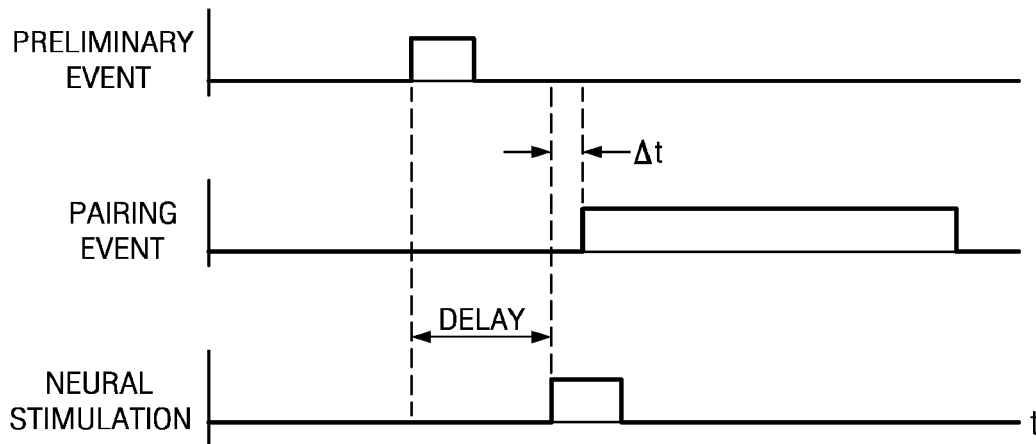

FIG. 27

1

TIMING CONTROL FOR PAIRED PLASTICITY

PRIORITY CLAIM

The present application is a continuation of application Ser. No. 13/941,986, filed Jul. 15, 2013, entitled TIMING CONTROL FOR PAIRED PLASTICITY, which is a division of application Ser. No. 12/485,857, filed Jun. 16, 2009, entitled TIMING CONTROL FOR PAIRED PLASTICITY, which is a continuation application of U.S. Utility patent application Ser. No. 12/485,040, filed Jun. 15, 2009 and claims priority benefits under 35 U.S.C. § 119(e) from Provisional Application No. 61/077,648, filed on Jul. 2, 2008 and entitled "Treatment of Tinnitus with Vagus Nerve Stimulation"; U.S. Provisional Application No. 61/078,954, filed on Jul. 8, 2008 and entitled "Neuroplasticity Enhancement"; U.S. Provisional Application No. 61/086,116, filed on Aug. 4, 2008 and entitled "Tinnitus Treatment Methods and Apparatus"; and U.S. Provisional Application No. 61/149,387, filed on Feb. 3, 2009 and entitled "Healing the Human Brain: The Next Medical Revolution." The present application incorporates the foregoing disclosures herein by reference.

BACKGROUND

The present disclosure relates generally to therapy, rehabilitation and training including induced plasticity. More particularly, the disclosure relates to methods and systems of enhancing therapy, rehabilitation and training using nerve stimulation paired with training experiences.

SUMMARY

For purposes of summarizing the invention, certain aspects, advantages, and novel features of the invention have been described herein. It is to be understood that not necessarily all such advantages may be achieved in accordance with any particular embodiment of the invention. Thus, the invention may be embodied or carried out in a manner that achieves or optimizes one advantage or group of advantages as taught herein without necessarily achieving other advantages as may be taught or suggested herein.

BRIEF DESCRIPTION OF THE DRAWINGS

The disclosed inventions will be described with reference to the accompanying drawings, which show important sample embodiments of the invention and which are incorporated in the specification hereof by reference, wherein:

FIG. 1 is a block diagram depicting a paired training system, in accordance with an embodiment;

FIG. 2 is a block diagram depicting a paired training system affecting a sub-cortical region, in accordance with an embodiment;

FIG. 3 is a block diagram depicting a paired training system affecting the nucleus basalis, in accordance with an embodiment;

FIG. 4 is a block diagram depicting a paired training system affecting the locus coeruleus, in accordance with an embodiment;

FIG. 5 is a block diagram depicting a paired training system affecting the amygdala, in accordance with an embodiment;

FIG. 6 is a block diagram depicting a paired training system affecting the nucleus of the solitary tract (NTS), in accordance with an embodiment;

2

FIG. 7 is a block diagram depicting a paired training system affecting the cholinergic system, in accordance with an embodiment;

FIG. 8 is a block diagram depicting a paired training system affecting the noradrenergic system, in accordance with an embodiment;

FIG. 9 is a simplified diagram depicting a stimulator, in accordance with an embodiment;

FIG. 10 is a simplified diagram depicting a wireless stimulator, in accordance with an embodiment;

FIG. 11 is a simplified diagram depicting a dual stimulator configuration, in accordance with an embodiment;

FIG. 12 is a simplified diagram depicting a multi-stimulator configuration, in accordance with an embodiment;

FIG. 13 is a graph depicting a constant current stimulation pulse, in accordance with an embodiment;

FIG. 14 is a graph depicting an exponential stimulation pulse, in accordance with an embodiment;

FIG. 15 is a graph depicting a train of constant current stimulation pulses, in accordance with an embodiment;

FIG. 16 is a block diagram depicting a synchronizing control system, in accordance with an embodiment;

FIG. 17 is a graph depicting synchronized pairing, in accordance with an embodiment;

FIG. 18 is a block diagram depicting a response control system, in accordance with an embodiment;

FIG. 19 is a graph depicting response pairing, in accordance with an embodiment;

FIG. 20 is a block diagram depicting a manual control system, in accordance with an embodiment;

FIG. 21 is a graph depicting manual pairing, in accordance with an embodiment;

FIG. 22 is a block diagram depicting a closed loop control system, in accordance with an embodiment;

FIG. 23 is a graph depicting closed loop pairing, in accordance with an embodiment;

FIG. 24 is a block diagram depicting an initiated control system, in accordance with an embodiment;

FIG. 25 is a graph depicting initiated pairing, in accordance with an embodiment;

FIG. 26 is a block diagram depicting a delayed response timing control system, in accordance with an embodiment; and

FIG. 27 is a graph depicting delayed response pairing, in accordance with an embodiment.

DETAILED DESCRIPTION OF THE DRAWINGS

The numerous innovative teachings of the present application will be described with particular reference to presently preferred embodiments (by way of example, and not of limitation). The present application describes several inventions, and none of the statements below should be taken as limiting the claims generally. Where block diagrams have been used to illustrate the invention, it should be recognized that the physical location where described functions are performed are not necessarily represented by the blocks. Part of a function may be performed in one location while another part of the same function is performed at a distinct location. Multiple functions may be performed at the same location.

With reference to FIG. 1, a paired training system is shown. A timing control system **106** is communicably connected to a neural stimulator system **108** and a training system **110**. Receiving timing instruction from the timing control system **106**, the neural stimulator system **108** provides stimulation to a nerve **104**. Similarly receiving timing instruction from the timing control system **106**, or providing timing instruction to

the timing control system, the training system **110** generates desired mental images, ideas, formations or states in the brain **102**. The stimulation of the nerve **104** affects the brain **102** by inducing plasticity. The temporally paired combination of training and stimulation generates manifestations of plasticity in the brain **102** that may be measured by a plasticity measure system **112**.

The timing controls system **106** generally provides the simultaneous nature of the pairing. The stimulation and the training are simultaneous in that they occur at the same time, that is, there is at least some overlap in the timing. In some embodiments, the stimulation may lead the start of the training while in other embodiments, the stimulation may follow the start of the training. In many cases, the stimulation is shorter in duration than the training, such that the stimulation occurs near the beginning of the training. Plasticity resulting from stimulation has been shown to last minutes or hours, so a single stimulation pulse may suffice for the whole duration of extended training.

In the treatment of tinnitus, for example, the training may consist of brief audible sounds including selected therapeutic frequencies, paired with stimulations. Because the duration of the sounds may be short, the timing may be controlled very precisely so that the sound coincides temporally with the stimulation. This kind of precision may typically require some form of computer control. In other forms of rehabilitation or education, the timing of the training and/or the stimulation may be controlled manually. Further therapies and training may include training triggered timing or physical condition feedback to provide a closed-loop system.

The neural stimulation system **108** may provide stimulation of the nerve **104** using electrical stimulation, chemical stimulation, magnetic stimulation, optical stimulation, mechanical stimulation or any other form of suitable nerve stimulation. In accordance with an embodiment, an electrical stimulation is provided to the left vagus nerve. In an electrical stimulation system, suitable stimulation pulses may include a variety of waveforms, including constant current pulses, constant voltage pulses, exponential pulses or any other appropriate waveform. An electrical stimulation system may use a single stimulation pulse or a train of stimulation pulses to stimulate the nerve **104**. Stimulation parameters are selected to affect the brain **102** appropriately, with reference to the affected brain regions or systems, plasticity measures, desynchronization or any other appropriate stimulation parameter measure. A half second train of biphasic stimulation pulses, with a pulse width of 100 microseconds, at 0.8 milliamps and at 30 Hz has been used effectively in the treatment of tinnitus.

Paired stimulation could be accomplished using deep brain stimulation, cortical stimulation, transcranial magnetic stimulation and any other suitable neural stimulation.

One indication of appropriate stimulation may be desynchronization of the cortical EEG. A 0.8 milliamp pulse has been shown to cause cortical desynchronization at frequencies between 30 and 150 Hz. 0.4 milliamp pulses desynchronize the cortex at higher frequencies of 100 to 150 Hz. Desynchronization has been shown to last for at least four seconds in response to stimulation of the vagus nerve.

The simultaneous training system **110** generates the sensory input, motor sequences, cognitive input, mental images, ideas, formations or states that are to be retained by the brain **102**. A training system **110** may provide sensory information, such as visual, auditory, olfactory, tactile or any other suitable sensory information. Training system **110** may include physical therapies, cognitive therapies, emotional therapies, chemical therapies, or any other suitable therapies. Training system **110** may present educational information. Training

system **110** may include the subject, physically, mentally, emotionally or in any other suitable fashion. Training system **110** may include teachers, doctors, therapists, counselors, instructors, coaches or any other suitable training provider. Training system **110** may evoke specific patterns of neural activity by direct brain stimulation, for example by electrical, magnetic, optical, or any other suitable pattern evocation systems. Training system **110** may inactivate specific brain regions via chemical agents, cooling, magnetic stimulation, or other suitable methods.

The paired training system of FIG. **1** affects the brain **102** to generate plasticity that can be measured by a plasticity measure system **112**. In the treatment of tinnitus, a cortical map may be used to measure the map distortion and correction that accompanies the successful treatment of tinnitus. Less invasively, the plasticity can be measured by behaviorally reactions to stimuli, such as a startle test for tinnitus. Further, plasticity can be measured by inquiring about the subjective experience of a subject. If a tinnitus patient no longer experiences a persistent noise, plasticity has been measured.

With reference to FIG. **2**, a paired training system affecting a subcortical region **114** of the brain **102**, in accordance with an embodiment is shown. The stimulation of nerve **104** affects a subcortical region **114**. The subcortical region **114**, in turn, affects the brain to induce plasticity. Stimulation of nerves **104** such as the trigeminal nerve and other cranial nerves are known to affect the subcortical region **114**.

With reference to FIG. **3**, a paired training system affecting the nucleus basalis **116**, in accordance with an embodiment, is shown. The stimulation of nerve **104** affects the nucleus basalis **116**. The nucleus basalis, in turn, affects the brain **102** to induce plasticity.

With reference to FIG. **4**, a paired training system affecting the locus coeruleus **118**, in accordance with an embodiment, is shown. The stimulation of nerve **104** affects the locus coeruleus **118**. The locus coeruleus **118**, in turn, affects the brain **102** to induce plasticity.

With reference to FIG. **5**, a paired training system affecting the amygdala **120**, in accordance with an embodiment, is shown. The stimulation of nerve **104** affects the amygdala **120**. The amygdala **120**, in turn, affects the brain **102** to induce plasticity.

With reference to FIG. **6**, a paired training system affecting the NTS **122**, in accordance with an embodiment, is shown. The stimulation of nerve **104** affects the NTS **122**. The NTS **122**, in turn, affects the brain **102** to induce plasticity.

With reference to FIG. **7**, a paired training system affecting the cholinergic system **124**, in accordance with an embodiment, is shown. The stimulation of nerve **104** affects the cholinergic system **124**. The cholinergic system **124** releases acetylcholine (ACh) into the brain **102** inducing plasticity.

With reference to FIG. **8**, a paired training system affecting the noradrenergic system **126**, in accordance with an embodiment, is shown. The stimulation of nerve **104** affects the noradrenergic system **126**. The noradrenergic system **126** releases noradrenaline (NE) into the brain **102** inducing plasticity.

With reference to FIG. **9**, a neural stimulator system, in accordance with an embodiment, is shown. A neural stimulator control **109** is communicably connected to a neurostimulator **128**. Neurostimulator **128** provides a stimulation pulse to a nerve **104** via a pair of electrodes **130a** and **130b**. Electrodes **103a** and **103b** could be cuff electrodes, conductive plates or any other suitable neural stimulation electrode. The neurostimulator may be powered by a piezoelectric powering system as well as near field inductive power transfer,

far-field inductive power transfer, battery, rechargeable battery or any other suitable neurostimulator power system. When neural stimulator control 109 receives timing instructions from a timing control system (not shown), the neural stimulator control 109 initiates a stimulation pulse from the neurostimulator 128 via electrodes 130a and 130b.

With reference to FIG. 10, a wireless neural stimulator system, in accordance with an embodiment is shown. Neurostimulator 128 communicates with the neural stimulation system 109 using an inductive transponder coil 132. The neural stimulator system 109 includes an external coil 134. Information may be communicated between the neural stimulator system 109 and the neurostimulator 128. Power may be transferred to the neurostimulator 128 by the neural stimulator system.

With reference to FIG. 11, a dual neurostimulator system, in accordance with an embodiment, is shown. Two neurostimulators 128 may stimulate neural 104. The neurostimulators may be controlled to reinforce each other, as redundancy, or to prevent efferent signals from projecting away from the brain.

With reference to FIG. 12, a multi-neurostimulator system, in accordance with an embodiment, is shown. A plurality of neurostimulators 128 may stimulate nerve 104. The neurostimulators may be controlled to reinforce each other, as redundancy, or to prevent efferent signals from projecting away from the brain.

With reference to FIG. 13, a graph shows a constant current stimulation pulse, in accordance with an embodiment.

With reference to FIG. 14, a graph shows an exponential stimulation pulse, in accordance with an embodiment.

With reference to FIG. 15, a graph shows a train of constant current stimulation pulses, in accordance with an embodiment.

With reference to FIG. 16, a synchronized timing control system, in accordance with an embodiment, is shown. The synchronized timing control system includes a synchronizing timing control 186. The synchronizing timing control 186 is communicably connected to the neural stimulation system 108 and the training system 110. The synchronizing timing control 136 provides timing instructions to the neural stimulation system 108 and the training system 110 so that the stimulation and training occur simultaneously. In the treatment of tinnitus, the stimulation of the nerve may slightly precede each training sound, to give the stimulation time to affect the brain when the training sound is presented. Further embodiments may include other suitable timing variations.

With reference to FIG. 17, a graph shows a possible timing relationship between event and stimulation for a synchronized timing control system.

With reference to FIG. 18, a response timing control system, in accordance with an embodiment, is shown. The response timing control system includes a response timing control 138. The response timing control 138 is communicably connected to the neural stimulation system 108 and a simultaneous event monitor 140. The response timing control 138 receives timing instructions from the event monitor 140 and provides timing instructions to the neural stimulation system 108, so that the stimulation and training occur simultaneously. Because the stimulation is generated in response to an event, the stimulation will generally lag the event by some finite time delta t. In cases where there is an event precursor that can be monitored, the timing can be made more exact.

With reference to FIG. 19, a graph shows a possible timing relationship between a monitored event and a nerve stimulation.

With reference to FIG. 20, a manual timing control system, in accordance with an embodiment, is shown. The manual timing control system includes a response timing control 138. The response timing control 138 is communicably connected to the neural stimulation system 108 and a manual input 142. The response timing control 138 receives timing instructions from the manual input 142 and provides timing instructions to the neural stimulation system 108, so that the stimulation and training occur simultaneously.

With reference to FIG. 21, a graph shows a possible timing relationship between an event, a manual input and a neural stimulation.

With reference to FIG. 22, a closed loop timing control system, in accordance with an embodiment, is shown. The closed loop timing control system includes a closed loop timing control 144. The closed loop timing control 138 is communicably connected to the neural stimulation system 108 and a sensor 146. The closed loop timing control 144 receives timing instructions from the sensor 146 and provides timing instructions to the neural stimulation system 108, so that the stimulation and training occur simultaneously.

With reference to FIG. 23, a graph shows a possible timing relationship between an sensed training event and a neural stimulation is shown.

Sensor 146 may monitor external or internal events, including heart-rate, blood pressure, temperature, chemical levels or any other parameter that may indicate a training event.

With reference to FIG. 24, a initiated timing control system, in accordance with an embodiment, is shown. The initiated timing control system includes an initiated timing control 148. The initiated timing control 148 is communicably connected to a neural stimulation system 106 and an event generator 150. The initiated timing control 148 receives timing information from the neural stimulation system 106, indicating that a nerve has been stimulated. The initiated timing control 148 provides timing instructions to the event generator 150, such as a therapeutic sound generator connected by Bluetooth, such that the event generator 150 generates an event during the stimulation pulse.

With reference to FIG. 25, a graph shows a possible timing relationship between a neural stimulation and an event generation.

With reference to FIG. 26, a delayed response timing control system, in accordance with an embodiment, is shown. The delayed response timing control system includes a delayed response timing control 152. The delayed response timing control 152 is communicably connected to a neural stimulation system 106 and a preliminary event sensor 154. The preliminary event sensor 154 detects a preliminary event that anticipates a pairing event. The delayed response timing control 148 receives timing information from the preliminary event sensor 154, indicating that a preliminary event has been detected. The delay response timing control 148 provides timing instructions to the neural stimulation system 106 to initiate nerve stimulation. In the depicted embodiment, the timing control 152 initiates the stimulation before the beginning of the pairing event, giving a negative delta t. A delay response timing system may initiate stimulation at the same time as the beginning of the pairing event, or after the beginning of the pairing event.

With reference to FIG. 27, a graph shows a possible timing relationship between a neural stimulation, a preliminary event and a pairing event.

The plasticity induced by neural stimulation can be paired with a variety of therapies, rehabilitation, training and other forms of personal improvement. Each therapy acts as a training source. The specific timing requirements associated with

each therapy are derived from the specifics of the therapy, such that the stimulation occurs during the training, and most effectively near the beginning of the training. Some possible therapies may include behavioral therapies such as sensory discrimination for sensory deficits, motor training for motor deficits, with or without robotic assistance and cognitive training/rehabilitation for cognitive deficits. Exercise and motor therapy could be paired to treat motor deficits arising from traumatic brain injury, stroke or Alzheimer's disease and movement disorders. Constraint induced therapy could be paired to help prevent the use of alternative strategies in order to force use of impaired methods. Speech therapy could be paired for speech and language deficits. Cognitive therapies could be paired for cognitive problems.

Sensory therapies, such as tones, could be paired to treat sensory ailments such as tinnitus. In treating tinnitus, the paired tones may be at frequencies distinct from the frequencies perceived by the tinnitus patient.

Exposure or extinction therapy could be paired to treat phobias or post-traumatic stress disorder.

Computer-based therapies such as FastForward for dyslexia, Brain Fitness Program Classic or Insight, could be paired to enhance their effects. Psychotherapy could be paired, as well as other therapeutic activities in the treatment of obsessive-compulsive disorder, depression or addiction.

Biofeedback therapy could be paired. For example, temperature readings or galvanic skin responses could be paired to treat anxiety or diabetes. An electromyograph could be paired to improve motor control after brain spinal or nerve damage. A pneumograph could be paired to improve breathing control in a paralyzed patient. A real-time fMRI could be paired to improve pain control or treat OCD. An electrodermograph, EEG, EMG or electrocardiograph could be paired to treat disorders such as anxiety. An electroencephalograph could be paired to treat epilepsy. An hemoencephalography could be paired to treat migraines. A photoplethysmograph could be paired to treat anxiety. A capnometer could be paired to treat anxiety. Virtual reality therapy could be paired to treat disorders such as addiction, depression, anxiety or posttraumatic stress disorder. Virtual reality therapy could also be paired to enhance cognitive rehabilitation or performance. Drug therapies could be paired to treat a variety of conditions. Amphetamine-like compounds could be paired to enhance neuromodulators and plasticity. SSRI's could be paired to enhance neuromodulators and plasticity. MOA inhibitors could be paired to enhance neuromodulators and plasticity. Anti-coagulants could be paired to act as clot busters during acute stroke. Various drugs could be paired to stop spasm after nerve or brain damage such as Botulinum toxin, Lidocaine, etc. Small doses of drugs of abuse could be paired to extinguish cravings in addicts.

Hormone therapy could be paired. For example, progesterone, estrogen, stress, growth, or thyroid hormone, etc. could be paired to treat traumatic brain injury or Alzheimer's disease. Glucose therapy could be paired to treat anxiety. Electrical or magnetic stimulation of the central or peripheral nervous system could be paired. For example, transcranial magnetic stimulation could be used to enhance or reduce activity in a specific brain area and thereby focus the directed cortical plasticity. Transcutaneous electrical nerve stimulation could be paired to treat chronic pain, tinnitus and other disorders. Subcutaneous electrical nerve stimulation could be paired to treat chronic pain. Stem cell therapy could be paired to treat disorders such as Parkinson's disease. Gene therapy could be paired to treat conditions such as Down's syndrome,

Huntington's disease or fragile X syndrome. Hyperbaric oxygen therapy could be paired to treat carbon monoxide poisoning

Multiple therapies could be paired simultaneously or sequentially.

None of the description in the present application should be read as implying that any particular element, step, or function is an essential element which must be included in the claim scope: THE SCOPE OF PATENTED SUBJECT MATTER IS DEFINED ONLY BY THE ALLOWED CLAIMS. Moreover, none of these claims are intended to invoke paragraph six of 35 USC section 112 unless the exact words "means for" are followed by a participle.

The claims as filed are intended to be as comprehensive as possible, and NO subject matter is intentionally relinquished, dedicated, or abandoned.

What is claimed is:

1. A system comprising:

a therapeutic training interface configured to provide tone based therapy to a patient;

a vagus nerve interface configured to provide electrical stimulation to a vagus nerve of the patient, wherein the system is configured to determine the beginning of the tone based therapy,

the system is configured to control stimulation to the vagus nerve and control the providing of the tone based therapy so that the stimulation to the vagus nerve and the providing of the tone based therapy is synchronized and the stimulation occurs after the beginning of the tone based therapy, and

the system is configured to control the therapeutic training interface and the vagus nerve interface so that at least one audible tone is provided to the patient followed by a waiting period followed the providing of at least one audible tone to the patient and wherein the respective at least one vagus nerve stimulations are paired with the at least one audible tones and so that at no audible tones and no vagus nerve stimulations are provided during the waiting period.

2. The system of claim 1, wherein:

the system is configured to control the therapeutic training interface to apply a series of audible tones to the patient in synchrony with the stimulation to the vagus nerve.

3. The system of claim 1, wherein:

the system is configured to control the therapeutic training interface and the vagus nerve interface such that at least one audible tone is provided to the patient followed by a waiting period followed the providing of at least one audible tone to the patient and so that respective at least one vagus nerve stimulations are paired with the at least one audible tones.

4. The system of claim 1, wherein:

the system is configured to control the therapeutic training interface and the vagus nerve interface such that at least one audible tone is provided to the patient followed by a waiting period followed the providing of at least one audible tone to the patient and so that respective at least one vagus nerve stimulations are paired with the at least one audible tones and such that at least one of no audible tones and no vagus nerve stimulations are provided during the waiting period.

5. The system of claim 1, wherein:

the system is configured to control the therapeutic training interface and the vagus nerve interface so that stimulation of the vagus nerve and providing of the audible tone temporally overlap.

9

- 6. The system of claim 1, wherein:
the system is configured to control the therapeutic training interface and the vagus nerve interface such that stimulation of the vagus nerve and providing of the audible tone are paired, and so that the temporal length of the stimulation of the vagus nerve is different than the temporal length of the providing of the audible tone to which the stimulation of the vagus nerve is paired. 5
- 7. The system of claim 1, wherein:
the system is configured so that stimulation of the vagus nerve by the vagus nerve interface is an exponential stimulation pulse. 10
- 8. The system of claim 1, wherein:
the system is configured so that stimulation of the vagus nerve by the vagus nerve interface is a train of discrete constant current stimulation pulses having a fixed duration and spaced at fixed intervals. 15
- 9. The system of claim 1, wherein the system is configured to control stimulation to the vagus nerve such that stimulation overlaps with the provided tone based therapy. 20
- 10. A system comprising:
a timing control system configured to treat tinnitus therapy comprising:
a sound generator configured to generate a plurality of sounds;
a vagus nerve stimulator configured to electrically stimulate a vagus nerve of a patient, wherein the timing control system is configured to synchronize stimulation of the vagus nerve with the generation of the plurality of sounds, 30
the system is configured to identify the respective beginnings of the respective generated sounds,
wherein the system configured to provide electrical stimulation of the vagus nerve that respectively begins after the respective beginnings of the respective generated sounds, and wherein 35
the system is configured to synchronize the sounds with the vagus nerve stimulation so that at least one sound is provided to the patient followed by a waiting period followed by the providing of at least one sound to the patient and wherein respective at least one vagus nerve stimulations are paired with the at least one sound and wherein no sound is provided during the waiting period. 40
- 11. The system of claim 10, wherein:
the sound generator is configured to generate sounds, wherein each sound consists of only one frequency. 45
- 12. The system of claim 10, wherein:
the system is configured to control the sound generator to generate sound randomly.

10

- 13. The system of claim 10, wherein:
the system is configured to control an intensity of the sound generated by the sound generator.
- 14. The system of claim 10, wherein:
the system is configured to control a duty cycle of a pulse train of the vagus nerve stimulator so that the vagus nerve stimulation is followed by a period of non-stimulation at least as long as the length of time of the vagus nerve stimulation precedent the period of non-stimulation.
- 15. The system of claim 10, wherein:
the vagus nerve stimulator includes an electrode and a pulse generator connected to the electrode.
- 16. The system of claim 10, wherein the timing control system is configured to provide stimulation of the vagus nerve that overlaps with the generation of sound.
- 17. The system of claim 10, wherein the system is configured to send a series of stimulation trigger signals to the vagus nerve stimulator so that an electrical pulse train is provided so that the vagus nerve is stimulated with the electrical pulse train at the same time as the generation of the plurality of sounds.
- 18. The system of claim 10, wherein the system is configured to cause the sound generator to generate the plurality of sounds randomly. 25
- 19. A system, comprising:
a therapeutic training interface configured to provide sound to a patient;
a vagus nerve interface configured to provide electrical stimulation to a vagus nerve of the patient, wherein the system is configured to control the electrical stimulation to the vagus nerve and control the providing of the sound so that the stimulation to the vagus nerve and the providing of the sound is synchronized,
the system is configured to identify the beginning of the providing of sound to the patient,
the system configured to provide stimulation of the vagus nerve that begins after the beginning of the provided sound, and
the system is configured to synchronize the sounds with the vagus nerve stimulation so that a plurality of respective sounds are provided to the patient, and wherein the system is configured to provide a waiting period between the respective provided sounds defined by a period where no sound is provided, and wherein respective at least one vagus nerve stimulations are paired with the respective sounds. 30

* * * * *