

**CRWR Online Report 06-02**

**Water Quality Performance of a Batch Type Stormwater  
Detention Basin**

by

John R. Middleton, B.S.E.E, M.S.E.

Michael E. Barrett, Ph.D.

Joseph F. Malina, Jr., Ph.D.

May 2006

(revised July 2006)

Center for Research in Water Resources

The University of Texas at Austin

J.J. Pickle Research Campus

Austin, TX 78712-4497

This document is available online via the World Wide Web at

<http://www.crwr.utexas.edu/online.shtml>

## **Acknowledgements**

This project was funded by the Texas Department of Transportation under contract number 14-5XXIA005 (Project 04-0323).

## Table of Contents

List of Tables .....	vi
List of Figures .....	vii
List of Figures .....	vii
<b>CHAPTER 1 INTRODUCTION</b>	<b>1</b>
1.1 Background .....	1
1.2 Regulatory Summary .....	3
1.3 Scope of Work .....	5
<b>CHAPTER 2 LITERATURE REVIEW</b>	<b>7</b>
2.1 Detention Basins .....	7
2.2 Physical Characteristics of Suspended Solids.....	7
2.3 Hydraulic Residence Time.....	9
2.4 Dynamic Conditions .....	10
2.5 Outlet Structures .....	11
2.6 Measuring Suspended Solids .....	12
2.7 Existing Studies on Extending Retention Methods .....	13
2.8 Summary .....	14
<b>CHAPTER 3 MATERIALS AND METHODS</b>	<b>15</b>
3.2 Site Description.....	16
3.3 Meteorological Description .....	18
3.4 Study Site – Pond 3.....	19
3.5 Pond 3 Modifications .....	22
3.5.1 Sand Filter Media Removal .....	22

3.6 Automatic Controller Design and Installation .....	24
3.6.1 System Requirements.....	24
3.6.2 Theory of Operation.....	25
3.6.3 Valve/Actuator .....	26
3.6.4 Power .....	27
3.6.5 Programmable Logic Controller .....	28
3.6.6 Sensor.....	28
3.6.7 Relays.....	28
3.6.8 Enclosure.....	29
3.6.9 Implementation .....	29
3.6.10 Programming.....	31
3.6.11 Installation.....	36
3.7 Monitoring Equipment.....	38
3.7.1 Inflow Sampler.....	38
3.7.2 Outflow Sampler.....	40

3.8 Analytical Procedure.....	43
<b>CHAPTER 4 RESULTS</b>	<b>44</b>
4.1 Preliminary Monitoring .....	44
4.2 Sampling Issues .....	44
4.3 Storm Characteristics .....	46
4.4 Controller Operation .....	47
4.5 Monitoring Results.....	49
4.6 Hypothesis Testing.....	53
<b>CHAPTER 5 CONCLUSIONS AND RECOMMENDATIONS</b>	<b>56</b>
References.....	59
Appendix A.....	63
Appendix B – Controller Bill of Materials .....	77
Appendix C – Controller Operation and Maintenance .....	78

## List of Tables

Table 1	Leading Sources of Water Quality Impairment.....	1
Table 2	Typical Constituent Concentrations by Land Use .....	2
Table 3	TSS Removal of Selected BMPs .....	2
Table 4	TSS Performance Standards for Selected Locations .....	4
Table 5	Representative Calculated Settling Velocities.....	8
Table 6	Analysis of Highway Runoff Composite Samples .....	9
Table 7	Controller Power Consumption.....	27
Table 8	Time Based Sampling Program for Outflow Sampler.....	41
Table 9	Parameters for Analysis by Environmental Laboratory Services.....	43
Table 10	Preliminary Sampling Results .....	44
Table 11	Storm Characterization .....	47
Table 12	Storms Categorized by Use Case.....	48
Table 13	Pond 3 Data.....	50
Table 14	Summary of Sampling Results .....	51
Table 15	Influent and Effluent Concentration Comparison.....	52
Table 16	TSS Removal Comparison.....	53
Table 17	P-values for Constituents .....	55

## List of Figures

Figure 1 Typical Outlet Structure .....	12
Figure 2 Austin Sand Filter Layout .....	15
Figure 3 Map of Study Site.....	16
Figure 4 Arial Photograph of Study Site.....	17
Figure 5 TCEQ Map Showing Edwards Aquifer and Study Site .....	18
Figure 6 Average Annual Rainfall and Temperature in Austin Texas .....	19
Figure 7 Original Layout of Pond 3.....	20
Figure 8 Photo of Original Extended Detention Basin Configuration.....	21
Figure 9 Photo of the Original Sand Filter Basin .....	22
Figure 10 Photo of Modified Sand Filter Outlet Modifications .....	23
Figure 11 Photo of Modified Outlet.....	24
Figure 12 Block Diagram of Controller Circuit.....	26
Figure 14 Photo of Controller as Implemented.....	29
Figure 15 Controller Schematic .....	30
Figure 16 PLC Program Use Cases .....	32
Figure 17 PLC Program Flow Chart.....	34
Figure 18 Detailed view of PLC Control Program .....	35
Figure 19 Controller placement .....	37
Figure 20 Valve and Actuator.....	37
Figure 21 Float Switch.....	38
Figure 22 Inlet Sensor and Sampler Intake Placement .....	39
Figure 23 Inflow Sampler and Flow Meter.....	39

Figure 24 Outlet Sensor Placement.....	42
Figure 25 Outflow Sampler and Flow Meter.....	42
Figure 26 Rainfall During Study Period.....	46
Figure 27 Example of Use Case 3 Storm.....	48
Figure 28. Example of Use Case 1 Storm.....	49
Figure 29 Influent TSS log Normal Probability Plot.....	54
Figure 30 Effluent TSS log Normal Probability Plot.....	54



# CHAPTER 1 INTRODUCTION

## 1.1 Background

Nonpoint source pollution is a significant source of the total contaminants entering receiving water bodies in the United States. The major sources of nonpoint source pollution in river, lakes, and estuaries are agricultural runoff and urban runoff. The National Water Quality Inventory: 2000 Report to Congress identified eleven pollution source categories (USEPA, 2005). Urban runoff and storm sewers were shown to be the second leading source of water impairment in estuaries, the third in lakes, and the fourth in rivers as shown in Table 1.

Table 1 Leading Sources of Water Quality Impairment Related to Human Activities for Rivers, Lakes, and Estuaries (USEPA, 2005).

<b>Rivers and Streams</b>	<b>Lakes, Ponds, and Reservoirs</b>	<b>Estuaries</b>
Agriculture (48%) <sup>a</sup>	Agriculture (41%) <sup>a</sup>	Municipal point sources (37%) <sup>a</sup>
Hydrologic modifications (20%)	Hydrologic modifications (18%)	Urban runoff/storm sewers (32%)
Habitat modifications (14%)	Urban runoff/storm sewers (18%)	Industrial discharges (26%)
Urban runoff/storm sewers (13%)	Misc. nonpoint source pollution (14%)	Atmospheric deposition (24%)

Values in parentheses represent the percentage of assessed river miles, lake acres, or estuary square miles that are classified as impaired. States assessed 19% of stream miles, 43% of lakes, ponds, and reservoirs, and 36% of square mileage of estuaries.

<sup>a</sup> Excluding unknown, natural, and “other” sources.

The typical constituents and their concentrations that were observed in urban stormwater runoff are listed in Table 2.

Many constituents found in urban runoff occur in particulate form. In addition, suspended solids have been shown to carry significant amounts of other pollutants bound to their surface. Suspended solids are used as a surrogate to monitor pollutant removal levels in urban runoff controls because of the correlation between suspended solids and other constituents. State and local regulatory agencies typically define performance of stormwater treatment in terms of removal efficiencies of specific constituents. The constituent most often regulated in stormwater treatment BMPs is total suspended solids (TSS).

Table 2 Typical Constituent Concentrations by Land Use in Urban Stormwater Runoff (USEPA, 2005).

Typical Pollutants Found in Storm Water Runoff	Units	Residential	Mixed	Commercial	General Urban
Total suspended solids	mg/L	101	67	69	80
Total phosphorus	mg/L	383	263	201	0.30
Total nitrogen	mg/L	–	–	–	2.0
Total Kjeldahl nitrogen	mg/L	1.9	1.3	1.2	–
Nitrate + Nitrite	µg/L	736	558	572	–
Total organic carbon	mg/L	–	–	–	12.7
Biological oxygen demand	mg/L	10	7.8	9.3	–
Chemical oxygen demand	mg/L	73	65	57	–
Fecal coliform bacteria	MPN/100 mL	–	–	–	3600
<i>E. coli</i> bacteria	MPN/100 mL	–	–	–	1450
Petroleum hydrocarbons	mg/L	–	–	–	3.5
Oil and grease	mg/L	–	–	–	2 to 10
Cadmium	µg/L	–	–	–	2
Copper	µg/L	33	27	29	10
Lead	µg/L	144	114	104	18
Zinc	µg/L	135	154	226	140
Chlorides (winter only)	mg/L	–	–	–	230
Insecticides	µg/L	–	–	–	0.1 to 2.0
Herbicides	µg/L	–	–	–	1 to 5.0

A variety of stormwater controls, or Best Management Practices (BMPs), have been designed to treat stormwater runoff in urban areas. State and local authorities often provide guidelines for BMP design. In most cases, the recommended BMPs can be constructed in a cost effective manner and will provide the required TSS removal. BMPs that are used include wet ponds, extended detention basins, and sand filters. Common BMPs that are used in treating stormwater runoff, and TSS removal rates are listed in Table 3. However, recommended BMPs may be difficult to implement for either economic or technical reasons in some areas.

Table 3 TSS Removal of Selected BMPs (Barrett, 1999)

BMP	TSS Reduction (%)
Retention/Irrigation	100
Ext. Detention Basin	75
Grassy Swales	70
Vegetated Filter Strips	85
Sand Filters	89
Wet Basins	93
Constructed Wetlands	93

Much of the city of Austin, including the study area, is located over the Edwards Aquifer. The Edwards Aquifer is a limestone karst formation that is protected by regulations enacted by the City of Austin and State of Texas. The area's karst features provide conduits that allow surface water to quickly enter the aquifer. Two regions of the Edwards Aquifer are important to stormwater regulations – the contributing zone and the recharge zone. The contributing zone is the area where stormwater runoff collects and feeds streams that eventually flow to the recharge zone. The recharge zone is an area where the actual Edwards Limestone formation is exposed. Surface water in the recharge zone can quickly enter the aquifer through faults and fractures. The study area is located in the recharge zone and is subject to strict water treatment regulations.

## **1.2 Regulatory Summary**

Several key federal laws are instrumental in regulating the quality of stormwater treatment. The Water Pollution Control Act Amendments of 1972, which amended the Federal Water Pollution Control Act of 1948, established the National Pollutant Discharge Elimination System (NPDES). NPDES created a permitting system for point source discharges. Nonpoint sources were originally exempt from the NPDES program. The Clean Water Act of 1977 primarily addressed point source pollution and was responsible for regulating discharges from industrial and municipal sources. It extended some deadlines of the 1972 law, allowed municipalities to levee taxes to fund treatment projects, and emphasized area-wide treatment studies. It also initiated nonpoint source studies that led to the Nationwide Urban Runoff Program (NURP) to demonstrate the use of various urban runoff control measures. The 1987 Water Quality Act amended the Clean Water Act of 1972, established a permitting system for municipalities with populations over 250,000, and focused attention on nonpoint sources of pollution. Sources of nonpoint source pollution include urban runoff and agricultural runoff. Several court cases established that highway and urban runoff that is collected and discharged to receiving waters through pipes, ditches, or other conveyances or structures can be often considered a point source (Haested, 2003).

The Federal Safe Drinking Water Act of 1974 (SDWA) protects ground and surface waters which are used for drinking water supplies. The act regulates discharge of water, including stormwater, into groundwater systems through the Underground Injection Control (UIC) program. Contamination of receiving waters used as a drinking water supply is regulated by the SDWA (USEPA, 2004).

In addition, the Endangered Species Act of 1973 protects water quality when impairment of a water body can be linked to the decline of an endangered species (WMI 1997). Impaired water quality that is detrimental to the survival of an endangered species can trigger action as detailed in *Memorandum of Agreement Between the Environmental Protection Agency, Fish and Wildlife Service, and National Marine Fisheries Service Regarding Enhanced Coordination Under the Clean Water Act and the Endangered Species Act; Notice* (USEPA, 2001)

Regulations have been enacted to comply with federal water quality guidelines at state and local levels, particularly the 1987 Water Quality Act and the Safe Drinking Water Act of 1974. These regulations can be enacted statewide, or applied to certain regions or municipalities. In some cases, local authorities in environmentally sensitive areas, usually prompted by citizen groups, have gone beyond the federal guidelines and instituted stricter controls. The City of Austin, for example, has implemented more strict water quality controls within its jurisdiction than the State of Texas has implemented in the surrounding area.

Table 4 (USEPA, 2003) shows sample performance standards for total suspended solids (TSS) removal for selected areas. The data in the table indicates that 80 percent TSS removal is common across the country. Extended detention basins are estimated to provide 75% TSS removal (Barrett, 1999) and are therefore not appropriate for use in many areas. Wet ponds, sand filters, and retention/irrigation systems provide the required treatment for the jurisdictions in Table 4.

Table 4 TSS Performance Standards for Selected Locations (USEPA, 2003)

<b>Community/State</b>	<b>Standard</b>	<b>Criteria</b>	<b>Extended Detention Basin Appropriate?</b>
Delaware	Remove at least 80 percent of the annual TSS loading.	Treat the first inch of runoff by approved management practices.	No
Florida	Remove at least 80 percent of the average annual TSS loading.	Treatment volume varies from 0.5 to 1.5 inches depending on the practice.	No
New Jersey	80 percent reduction in TSS.	Treat runoff volume of a storm of >1.25inches in two hours or the one-yr, 24-hr storm.	No
South Carolina	Remove at least 80 percent of the average annual TSS loading.	Treatment volume varies from 0.5 to 1.0 inch depending on the practice.	No
Olympia, WA	80 percent removal of suspended solids.	Treat runoff volume of six-month, 24 hr storm	No
Orlando, FL	Reduce average annual TSS loading by 80 percent.	Treat first half-inch of runoff or the runoff from the first inch of rainfall, whichever is greater.	No
Winter Park, FL	Reduce average annual TSS loading by 80 percent.	Treat the first inch of runoff by retention.	No
Baltimore Co., MD	Remove at least 80 percent of the average annual TSS loading.	Treat the first half-inch of runoff from the site's impervious area	No
South Florida Water Management District	Remove at least 80 percent of the average annual TSS loading.	Treatment volume varies from 1.0 to 2.5 inches times percent impervious area.	No

Three governing bodies regulate stormwater treatment in the Austin Texas area, which is located over the environmentally sensitive Edwards aquifer. The Edwards Aquifer is a source of water for drinking, irrigation, and recreational use in the region. Most notably, the city of San Antonio, Texas draws most of its drinking water from the Edwards aquifer. The State of Texas, through the Texas Commission on Environmental Quality (TCEQ), through Title 30 of the Texas Administrative Code Chapter 213 (Title 30, 2006), also known as the Edwards Rules, regulates the treatment of stormwater runoff over the Edwards Aquifer. Approved BMPs that can be used in the area are specified in the Edwards Aquifer Technical Guidance Manual (TCEQ, 2006b). The Edwards rules require 80 percent removal of the increase in TSS caused by development of a parcel of land.

The City of Austin's Environmental Criteria Manual (COA, 2004) also details requirements for stormwater runoff treatment within specific aquifer zones that either directly recharge, or contribute to recharge of the aquifer. The City regulations require varying treatment levels depending on location relative to the Edward's Aquifer. Treatment levels range from removal efficiencies achieved using Austin sand filters, approximately 90% TSS removal, to no increase in annual load from the site for nine specific constituents: suspended solids, total phosphorus, total nitrogen, chemical oxygen demand, biochemical oxygen demand, total lead, cadmium, fecal coliform, fecal streptococci, volatile organic compounds, total organic carbon, pesticides, and herbicides (COA, 2004). The State of Texas, through legislation, provides a "grandfathering" mechanism which exempts some development from the current city watershed protection ordinances. (COA, 2006a)

The Lower Colorado River Authority (LCRA) implemented a nonpoint source pollution program to address pollution caused by stormwater runoff. The LCRA targets suspended solids, total phosphorus, and oil and grease in the Lower Colorado River Authority Highland Lakes Watershed Ordinance. Unlike the regulations of the City of Austin and the TCEQ which are designed to protect the Edwards Aquifer, the LCRA ordinance is targeted at preventing pollutants from entering lakes within the LCRA's jurisdiction. TSS removal of 70% to 90% of the increased load in stormwater runoff is required, depending on the location and slope of the site (LCRA, 2005). The LCRA recommends various BMPs in its Technical Manual (LCRA, 2006).

### **1.3 Scope of Work**

The objective of this research is the retrofit a non-performing extended detention basin of an Austin sand filter to operate as a batch reactor, and the evaluation of the performance of the modifications, based on TSS removal. Specifically, the research tasks were:

- Development of an automated controller to improve the control of hydraulic residence time of stormwater in the extended detention basin.

- Implementation and installation of the controller in an actual stormwater control structure.
- Monitoring the performance of the controller and the control of the influent and effluent from the basin during ten to twelve storms over a period of nine to twelve months.
- Evaluation of the performance of the controller, and the TSS removal of the basin compared to other BMPs and the TSS removal requirements.

## **CHAPTER 2 LITERATURE REVIEW**

### **2.1 Detention Basins**

The use of detention basins to treat stormwater in urban areas has been studied since the 1970s as a result of the emphasis on mitigating the effects of urban runoff. Detention basins were initially designed to control the peak flow of relatively short, high intensity rainfall events. The basins operate as flow control structures and release the captured water over a period of several hours through outlet structures or orifices; thereby, reducing the peak flow into receiving water bodies. These same structures could be used to treat the captured stormwater as well, by appropriate basin sizing and detention time selection (Randall and Grizzard, 1983).

Treatment processes in extended detention basins can be analyzed in terms of treatment processes in wastewater treatment. These processes are typically modeled using an idealized reactor or combination of reactors that pattern the flow in a given system. The reactor types commonly used are batch reactors, plug flow reactors (PF), and continuous flow stirred tank reactors (CFSTR) (Droste, 1997). Unfortunately, extended dry detention basins do not conform well to any of the three idealized reactors making analysis and modeling of their performance difficult and reducing their treatment effectiveness.

The primary treatment mechanism employed by extended detention basins is sedimentation. Flocculation is a secondary process that may also occur in extended detention basins (WERF, 2005). Sedimentation and flocculation are used to remove suspended particles in a treatment process. As mentioned in Chapter 1, suspended solids are used a surrogate for other pollutants in estimating pollutant removal in detention basins and other BMPs. Water captured by an extended detention basin is held for a predetermined residence time, during which, settling of suspended particles takes place (Randall and Grizzard, 1983).

### **2.2 Physical Characteristics of Suspended Solids**

Physical characteristics that affect settling of suspended solids are particle size and particle density. These characteristics can be used to predict the settling velocity of particles under ideal conditions using Stoke's Law for Settling.

$$v = \frac{\alpha(\rho_p - \rho_L)gd_p^2}{18\mu}$$

$v$  = settling velocity  $cm / s$

$\alpha$  = shape factor (1.0 for a sphere)

$g$  = acceleration due to gravity,  $cm / s^2$

$\rho_p$  = density of particle,  $g / cm^3$

$\rho_L$  = density of water,  $g / cm^3$

$d_p$  = diameter of particle,  $cm$

$\mu$  = viscosity of water (10° C),  $g / cm - s^2$

The value of 2.65 g/cm<sup>3</sup> is often used for the density of particles in stormwater runoff (Chapra, 1997). Recent work has shown that particle density in urban stormwater runoff is actually in the range of 0.81 g/cm<sup>3</sup> to 2.80 g/cm<sup>3</sup>, although the lower limit is thought to be greater than 1.0 g/cm<sup>3</sup> (Karamalegos et al., 2005). Representative settling velocities of various sized particles at two average particle densities calculated using Stoke's Law are presented in Table 5. Particles are assumed to have spherical shapes. The settling velocities can be used to determine the size of particles that will settle in a given depth of water in a given time period, and thereby determine detention basin sizing, and residence time requirements. A particle with a density of 2.65 g/cm<sup>3</sup> and diameters above 5 μm will settle in 12 hours from a depth of 1 m. Particles with a density of 1.1 g/cm<sup>3</sup> and diameters above 15 μm will settle in 12 hours from a 1 m depth. The relative settling rates illustrate the fact that lower density particles and smaller diameter particles settle more slowly. Settling velocity and particle size distributions can be used to estimate the particle removal in an ideal settling basin.

Table 5 Representative Calculated Settling Velocities

Particle Size (μm)	Settling Velocity(m/h)		Settling Distance in 12h (m)	
	ρ = 2.65 g/cm <sup>3</sup>	ρ = 1.1 g/cm <sup>3</sup>	ρ = 2.65 g/cm <sup>3</sup>	ρ = 1.1 g/cm <sup>3</sup>
200	137.1	15.7	1645.2	188.4
100	34.3	3.9	411.6	46.8
50	8.6	0.98	103.2	11.76
15	0.8	0.088	9.6	1.056
10	0.3	0.039	3.6	0.468
5	0.1	0.01	1.2	0.12

The results of various studies indicate that particles with a diameter greater than 20 μm can be removed in BMPs. Smaller particles do not settle effectively, most likely due to resuspension and turbulence present in many BMPs (WERF, 2005).



The range of particles sizes suspended in water can be characterized by the particle size distribution. A particle size distribution indicates the number of particles of a given diameter. Settling velocities and particle size distributions can be used to estimate removal rates in ideal settling basins. They can also be used to select residence times when designing detention basins.

Determining the particle size distribution in urban runoff is a difficult task. Several studies have been performed to characterize particle size distribution of urban runoff. In general, data indicates that in urban runoff, the particle count of small particles is greater than that of large particles. Since TSS is a measure of the mass concentration, and the volume of the particles (assumed to be spherical) is a function of the cube of the diameter, the mass concentration of smaller particles becomes less significant for TSS removals. Hamilton and Harrison (1991) report the particle distributions shown in Table 6. On average, 78% of the suspended solids are below 44  $\mu\text{m}$  in diameter.

Table 6 Analysis of Highway Runoff Composite Samples (Hamilton and Harrison, 1991)

Particle Size ( $\mu\text{m}$ )	Percent of suspended solids				mean value
	Sacramento Hwy 50	Harrisburg I-81	Milwaukee I-94	Effland I-85	
>250	1.54	6.10	14.56	3.58	6.45
88-250	9.07	6.70	7.00	1.3	6.02
44-88	10.70	11.70	5.84	8.06	9.08
<44	78.69	75.5	72.60	87.06	78.45

Greb and Bannerman (1997) examined a wet detention pond in an urban area of Madison Wisconsin (US) and found that over 90% of the particles were less than 62  $\mu\text{m}$  in diameter. A similar particle distribution was reported by Li et al., (2005) for highway sites in west Los Angeles with a similar particle distribution.

## 2.3 Hydraulic Residence Time

One of the design parameters available to engineers in the design of extended detention basins is residence time. Residence time is a critical design parameter and directly affects the removal of TSS in extended detention basins. The residence time in many BMPs is a function of the inflow rate and the outflow rate. The basin is typically filled quickly by stormwater conveyed through a storm drain or other conveyance, making the inflow time relatively short. The residence time is controlled by the size of an orifice installed on the outlet structure. The treated water is released slowly over a time period typically on the order of 24 to 48 hours, during which time sedimentation takes place. The first water entering the basin flows to the outlet, is discharged in a time much less than the average residence time, and therefore receives less treatment than

water entering the basin later. The last water to leave the basin has a longer residence time and is therefore has been treated for a longer period of time. The first water entering the basin often contains higher constituent concentrations (refer to first flush in Section 2.6 ) meaning that the water containing the highest constituent load is treated less than cleaner water.

Shammaa et al., (2002) recommend a range of optimal detention times from 24 to 40 h, and drawdown times of 24 h to achieve removal efficiencies of 60% based on studies of nine dry detention basins. Residence time of the captured water determines the size of particles that can possibly settle during the capture time of stormwater in an extended detention basin.

A set of design graphs to assist in extended dry detention basin design was developed by Papa & Guo (1999). The graphs assist regulatory agencies develop design guidelines. The graphs are based on models that consider rainfall duration, antecedent dry periods, and storage volume to develop detention time requirements.

## **2.4 Dynamic Conditions**

Hydraulic residence time can be affected by dynamic conditions in a BMP. Two important dynamic conditions are turbulence and short circuiting. These conditions cause resuspension of previously settled particles and contribute to the inability of some particles to settle in BMPs and results in the reduction of removal efficiencies. Extended detention basins have been shown to achieve discharge concentrations of 30 mg/L from influent concentrations of 150 mg/L (WERF, 2005). This discharge concentration is higher than that expected under ideal settling conditions as observed in studies in quiescent column settling experiments by Randall et al. (1982). Randall et al. determined that effluent TSS concentrations were a function of influent concentration and time of sedimentation. Effluent concentrations of 20 mg/L were achieved in 24 hours of settling in columns using grab samples of stormwater with TSS concentrations ranging from 38 mg/L to 721 mg/L. Reducing the short circuiting and turbulence in a BMP is therefore important in optimizing BMP performance.

Short circuiting is the flow of water directly from the detention basin inlet to the orifice resulting in a shorter residence time and a higher effluent concentration. Martin (1989) described tracer studies of detention basins to measure the mixing times and residence times of the basins. The study results indicate a qualitative relationship between discharge and storage that affects short circuiting that can significantly reduce the treatment effectiveness of a detention basin. High discharges and less storage reduced the amount of mixing in the basins due to short circuiting.

Flow patterns in a basin also can cause turbulence, which in turn resuspends previously settled particles by scouring, and interferes with the settling of previously suspended particles. This effect is similar to that seen in settling tanks in treatment

processes (Droste, 1997). Flow patterns in detention basins occur from flow leaving the basins outlet structure. Supporting the idea that resuspension occurs from dynamic conditions, Shammaa et al., (2002) describe two extended detention basins that have a combination inlet/outlet structure. The inflow/outflow pattern in the basins resulted in settling of suspended solids near the inlet/outlet resulting in a lower TSS removal efficiency.

## **2.5 Outlet Structures**

Outlet structures can affect suspended solids removal in several ways. The primary function of the outlet structure is the control of the flow rate of water leaving the basin. Screening of debris is also important to prevent blockage of the orifice by floating debris. The hydraulic residence time of the basin is controlled by sizing the orifice on the outlet structure. The orifice size is calculated to achieve a desired residence time for the water quality volume being treated using the standard orifice equation. Recommended methods of sizing an orifice are the use of a gate valve adjusted to the proper size, or the use an orifice plate over the outlet pipe to size the outlet (TCEQ, 2006b).

A recommended outlet structure is shown in Figure 1 (COA, 2004). The outlet structure consists of a perforated riser pipe that acts as an orifice during design storms, flood and emergency outlets, and trash screens to prevent blockage. The riser pipe is typically a minimum of 6 inches (100mm) in diameter with 1-inch perforations. Four perforations per row, with a spacing of 4-inches are typically recommended (TCEQ, 2006b). Perforated risers receive flow from multiple levels in the basin thereby reducing the effects of flow induced turbulence. Unfortunately, the water at the lower levels of the basin usually contains higher pollutant concentrations, resulting in the higher contaminant levels in the discharge from a perforated riser.

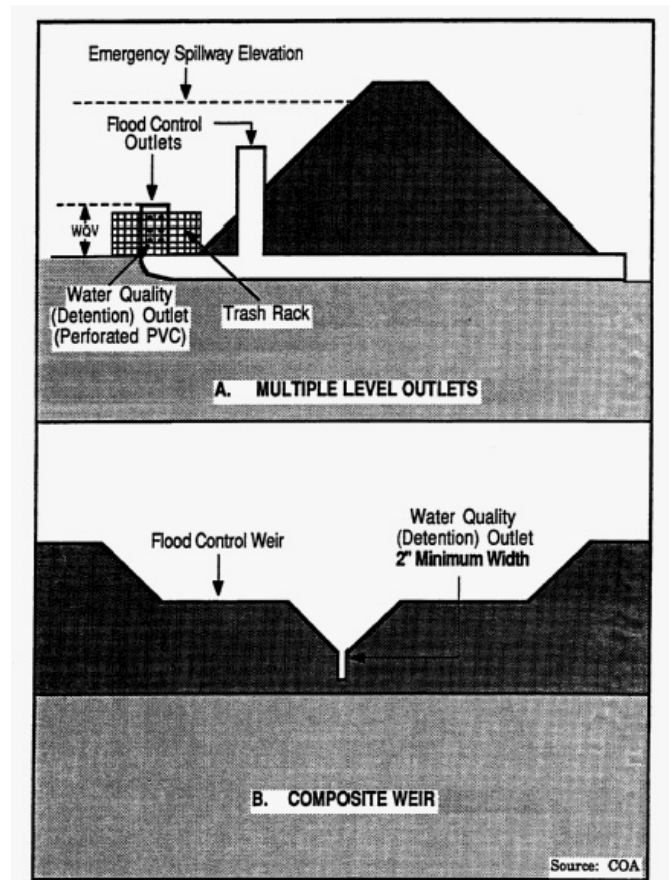

Figure 1 Typical Outlet Structure (COA, 2004)

## 2.6 Measuring Suspended Solids

There are several methods available for measuring the concentration of sediment and particulates suspended in a water sample. The most common method is Total Suspended Solids (TSS). TSS is routinely used by regulatory agencies as the regulated parameter in stormwater quality measurements. Alternative methods of measuring suspended solids are Suspended Solid Concentrations (SSC) and turbidity (Randall et al., 1982). TSS is the parameter most often monitored by regulatory agencies. TSS is similar to SSC, and differs primarily in the method used to obtain a sub-sample during

analysis. In SSC measurements, the entire sample is analyzed, while in TSS measurements a subsample is taken using a pipette. Standard procedures for measuring sediment concentrations in water are described in ASTM D 3977-97 (ASTM, 2002). Because larger particles cannot be removed using a pipette, TSS concentrations are often lower than SSC values (Gray et al., 2000). Since the TSS concentration is less than the actual suspended solids concentration, the calculated removal efficiency using TSS is less than the actual removal efficiency.

Influent pollutant concentrations in stormwater treatment are dependant on a variety of factors that also make analysis and modeling difficult. Urban runoff is driven by rainfall that falls on pervious and impervious areas in a watershed or catchment. The volume of runoff is related to the rainfall depth over the catchment. Impervious cover increases the volume of runoff and also increases the constituent load of the runoff. The rainfall depth and intensity also affect the concentration of constituents carried by the resulting runoff. First flush is a term for the physical process that describes the elevated amount of mass or concentration that is transported in the initial portion of a rainfall/runoff event (Sansalone and Cristina, 2004). Many BMPs are designed to treat the first flush volume of runoff during a rain event. Results of studies of the first flush effect (Stenstrom and Kayhanian, 2005 and Barrett et al., 1995) indicate that the first flush is highly variable, and is dependant on many other factors. This dependency makes the first flush difficult to quantify and predict.

## **2.7 Existing Studies on Extending Retention Methods**

Adler (1981) proposed an automatic device for emptying a detention basin by collecting water from the surface and discharging it at a constant rate. The surface collection device used in the study is a skimmer – a floating riser that collects water at the surface of the basin. In theory, the surface discharge is of a higher quality than that of a riser pipe. No performance data for this device was given. Skimmers have been studied further, but the retention time of a basin is not affected. The concept of a constant rate discharge, however, could be used to control the overall residence time.

Retention/Irrigation systems capture stormwater runoff and treat the water in a sedimentation basin. The treated water is pumped from the basin and used to irrigate nearby undeveloped land. Retention irrigation systems are used primarily in the Austin, Texas area. The sedimentation basin in a retention irrigation BMP is essentially an extended detention basin that holds stormwater runoff for a specified detention time, commonly 12 h, and the stored water is pumped through an irrigation system (COA, 2004). Retention irrigation systems are used in situations where 100% TSS removal efficiencies are required. No published data on the removal efficiency of the sedimentation basin of a retention/irrigation system is available.

## **2.8 Summary**

Extended detention basins are used as non-ideal sedimentation basins to remove suspended solids from urban stormwater runoff. Suspended solids are used a surrogate for other contaminants in urban runoff. Several characteristics of extended detention basins contribute to the non-ideal operation of the basins, including deviation from ideal sedimentation basin configurations, short circuiting, and outlet structures. As extended detention basin designs approach ideal conditions, suspended solids removal rates are more predictable and can be optimized.

## CHAPTER 3 MATERIALS AND METHODS

The design and implementation of an automatic controller used to provide flexible residence time control for an extended detention basin is described. The method of evaluating the performance of the modified BMP is also discussed.

The three storm water facilities considered in this research are BMPs that were initially designed to meet the requirements of the Edwards Rules. The recommended BMPs, Austin sand filters, were not properly constructed at the sites because of design errors. A typical Austin sand filter is shown in Figure 2. A sand filter treats water in two ways, first by sedimentation in a sedimentation basin and then by filtration in a sand filter.

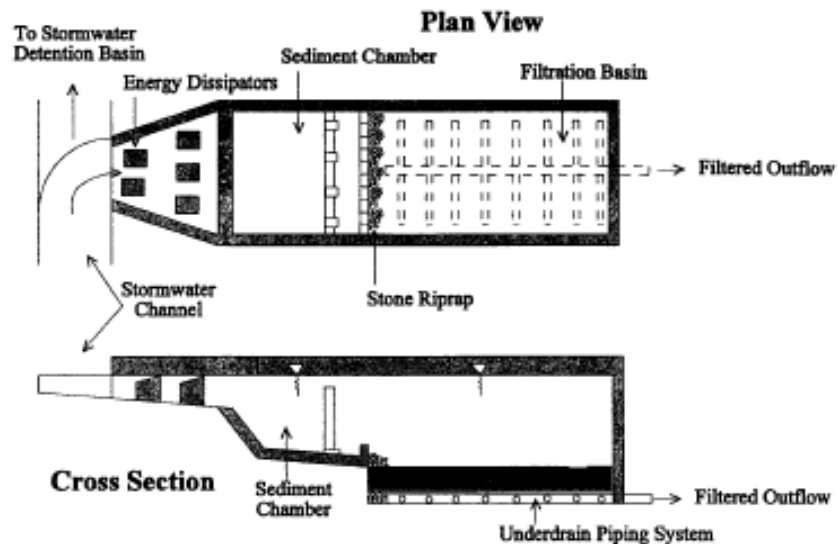

Figure 2 Austin Sand Filter Layout (COA, 2004)

The elevation head at the sites is not sufficient for proper Austin sand filters to be constructed. The BMPs were constructed in spite of the site issues. The TCEQ noticed the BMPs were not operating properly by observing the presence of standing water in the filtration basins and cited the BMPs as violating state regulations.

Evaluation of the construction of these BMPs and features of the sites suggested that an alternative design might bring the structures into compliance with TCEQ regulations without incurring excessive retrofit costs. A method of increasing the residence time in the BMPs in order to improve TSS removal was explored.

### 3.2 Site Description

The study site (Figure 3) is located on Anderson Mill Road in north Austin, Texas in Williamson County. The area is characterized by moderate density urban development and limited commercial property. Stormwater from the drainage area is conveyed

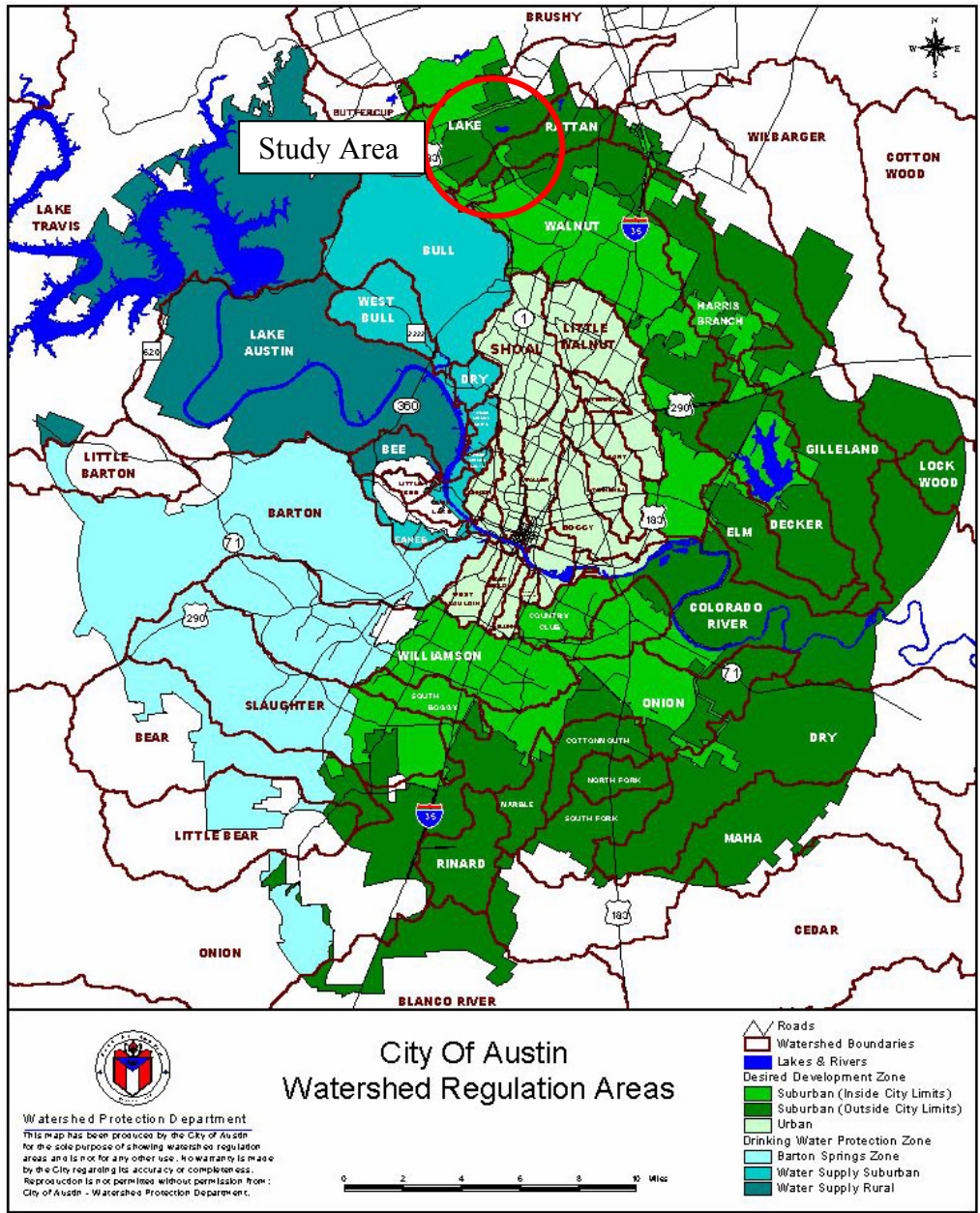

Figure 3 Map of Study Site (COA, 2006a)



through storm drains into an unnamed tributary of Lake Creek. Lake Creek flows into Bushy Creek which is part of the Brazos River watershed (Figure 4).

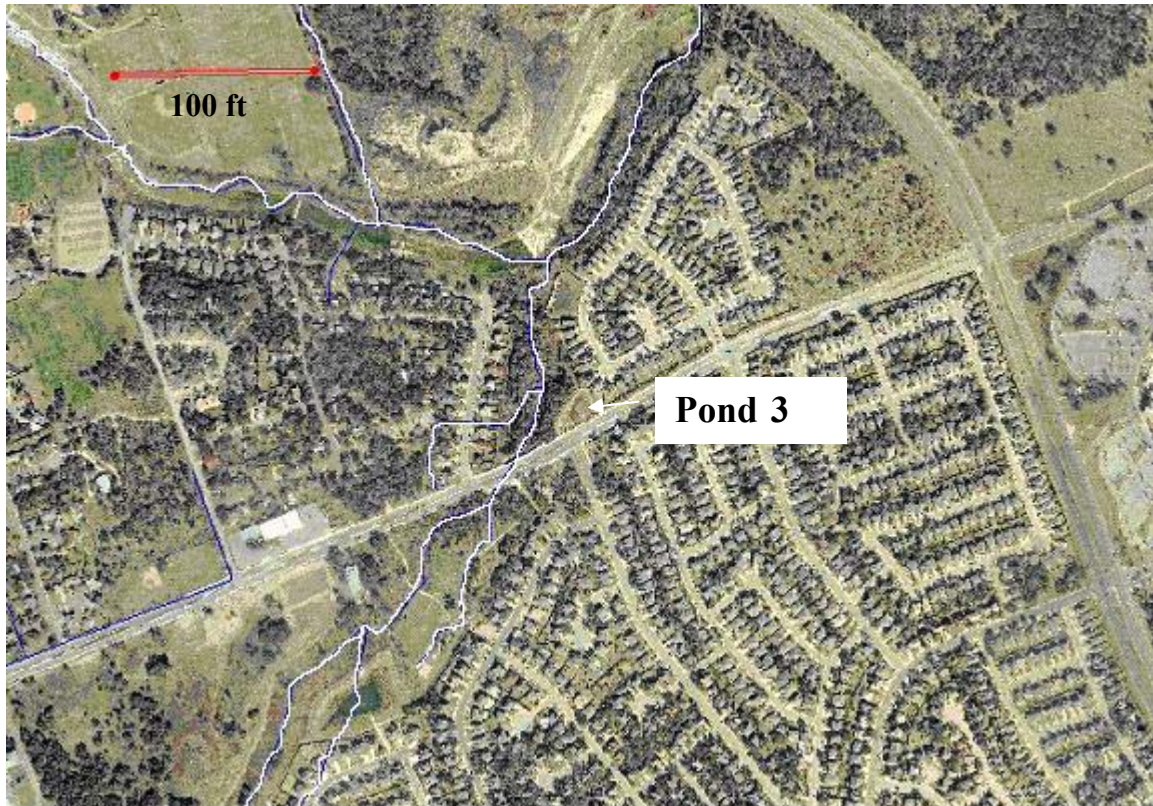

Figure 4 Aerial Photograph of Study Site (COA, 2006b)

Three Austin sand filters constructed as part of an expansion of Anderson Mill Road by TxDOT were evaluated as candidates for this study. The study area is over the Edwards aquifer recharge zone, as indicated by the light purple region in Figure 5. The area is subject to the TCEQ Edwards Rules requiring 80% TSS removal (Title 30 Texas Administrative Code Chapter 213). The original designs for the facilities had insufficient head in the filtration basin resulting in fouling of the filters. The BMPs required modifications to operate properly and were therefore considered for use in evaluating the concept of improved residence time control.

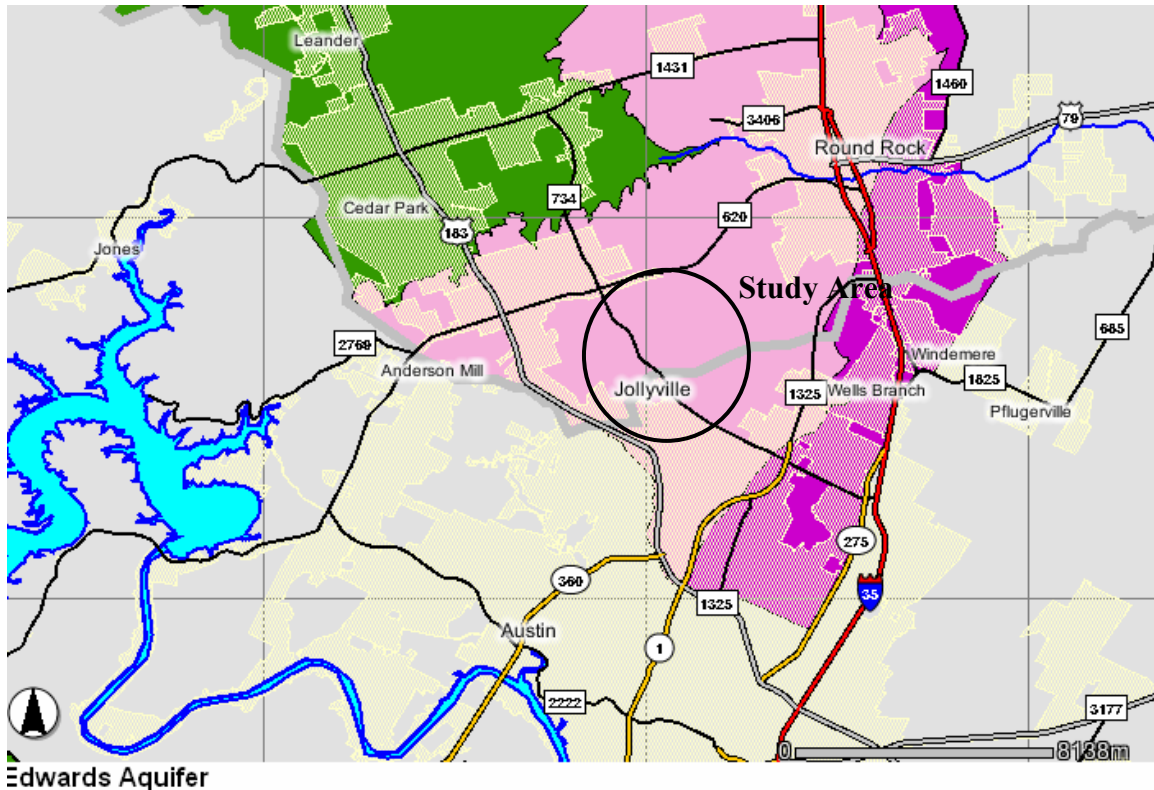

Figure 5 TCEQ Map Showing Edwards Aquifer and Study Site (TCEQ, 2006a).

One of the Austin sand filters, referred to as Pond 3 in this study, was chosen as the study site. Pond 1 had a relatively constant base flow which seemed to suggest that it was better suited to a wet pond design. The inlet to Pond 2 consisted of a 2 barrel box culvert making inflow monitoring difficult.

### 3.3 Meteorological Description

Austin’s historical average annual rainfall, collected at Camp Mabry, is 854.7 mm (33.65 inches) for the 30-year period from 1971 to 2000. Camp Mabry is located approximately 12 km (7.4 miles) south of the study site. Two periods of increased rainfall occur in May/June and in September/October. Monthly average rainfall is shown in Figure 4 (NCDC, 2006). Average monthly minimum and maximum temperatures for Camp Mabry are also shown Figure 6.

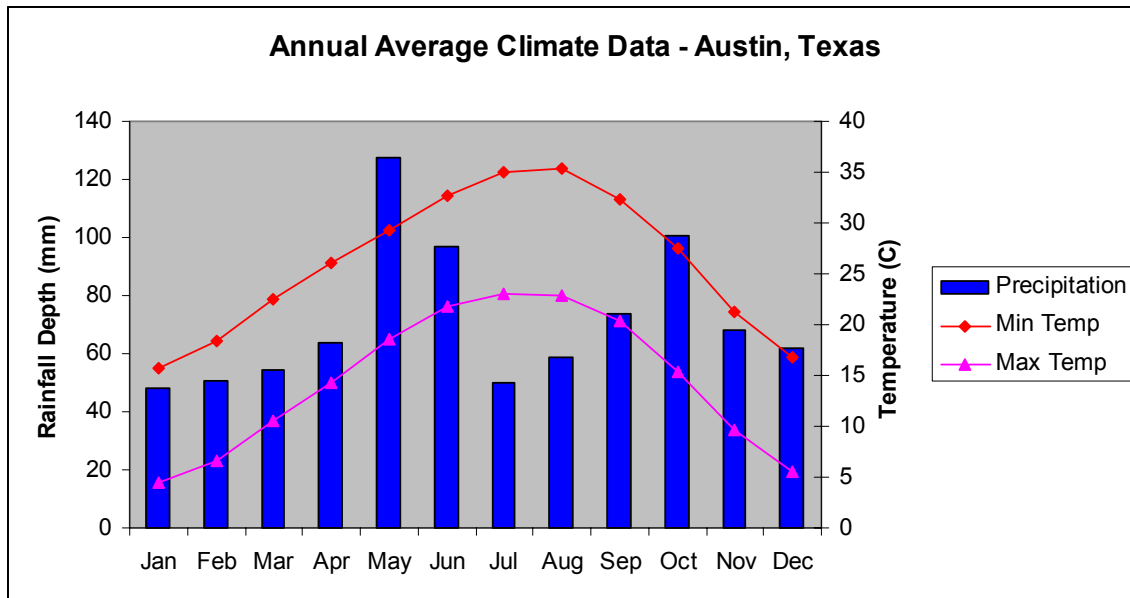

Figure 6 Average Annual Rainfall and Temperature in Austin Texas (NCDC, 2006)

### 3.4 Study Site – Pond 3

Pond 3 was designed as an Austin sand filter consisting of two basins: an extended detention basin to capture the required water quality volume and a sand filter to provide final treatment (Figure 7). Pond 3 was designed to meet the City of Austin’s sand filter requirements as described in the City’s Environmental Criteria Manual (COA, 2004). Pond 3 services a drainage area of 10.47 ha (25.9 acres), consisting of urban roadways and suburban single family residential units. Although it is located in the Texas hill country, there is only moderate elevation change in the watershed from a maximum of approximately 268.2 m (880 ft), to a minimum of 261.1 m (857 ft) at the sand filter outlet. The moderate elevation change presents challenges for meeting the minimum elevation required in constructing sand filters. The overall elevation change shown on the construction drawings from the inlet to the outlet is 26.2 mm (1.03 in).



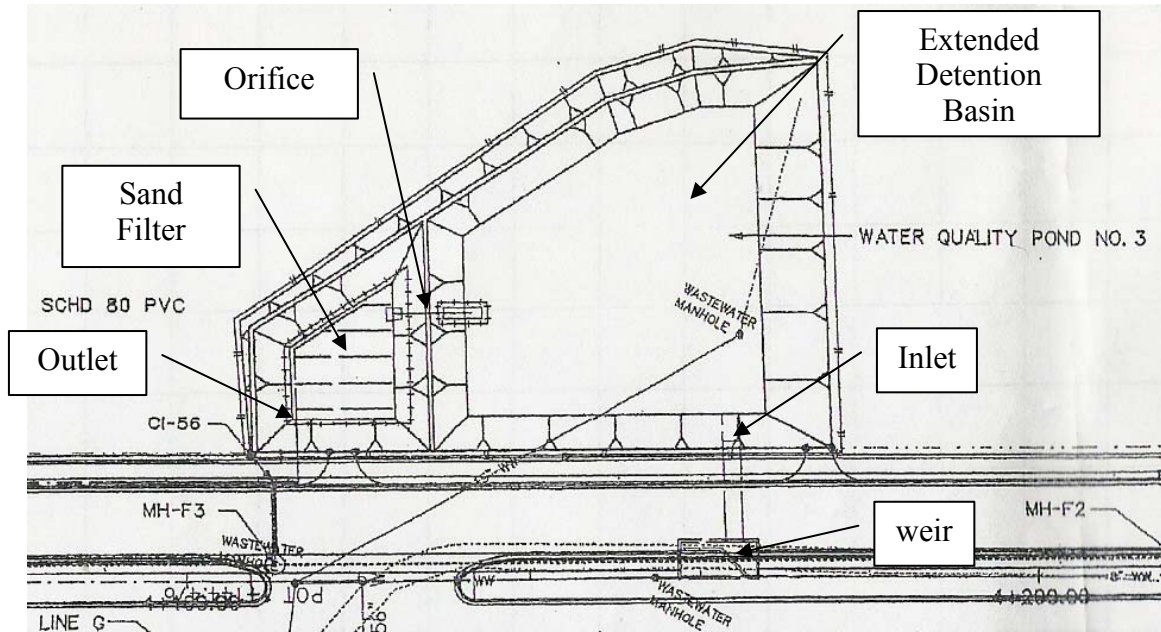

Figure 7 Original Layout of Pond 3

The extended detention basin of Pond 3 is roughly trapezoidal (Figure 8) with a surface area of about 1400 m<sup>2</sup> (14,900 ft<sup>2</sup>), and a volume of 1480 m<sup>3</sup> (52,200 ft<sup>3</sup>). The water quality depth is 0.78 m (2.6 ft) at the inlet. A weir diverts the first flush from the storm drain under Anderson Mill Road through a 17 m (55 ft) long 2100 mm x 900 mm box culvert. The water exits the box culvert and enters the sedimentation basin where it is slowed by three energy dissipaters located on a concrete apron. Approximately 10 m (33 ft) past the energy dissipaters, a concrete structure enclosing a sanitary sewer manhole causes a further deflection of the inflow. The elevation change from the inlet to the outlet of the extended detention basin is about 17 mm (0.7 in).

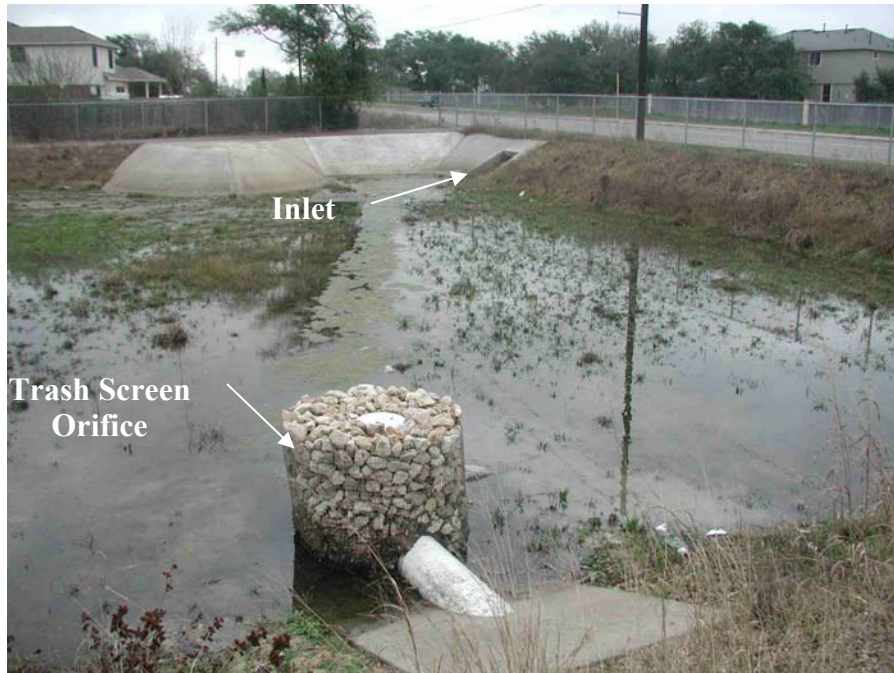

Figure 8 Photo of Original Extended Detention Basin Configuration

Water leaves the extended detention basin through an outlet structure consisting of a vertical perforated standpipe enclosed by a trash screen that connects to a 300 mm (12 in) pipe. A gate valve on the pipe provides emergency shut-off capability for hazardous waste spills. The gate valve was partially closed to increase the residence time of the runoff to approximately 12 hours.

The filtration basin, shown in Figure 9 is roughly trapezoidal with a surface area of about 148 m<sup>2</sup> (1590 ft<sup>2</sup>), and a volume of 380 m<sup>3</sup> (13,400 ft<sup>3</sup>). The sand filter nominally consists of 18 inches of sand above a system of perforated underdrain piping. The invert of the outlet of the filtration basin as constructed was at the level of the top of the sand layer, preventing filtration through the sand layer. The outflow of the basin returns to the storm drain, which then discharges into an unnamed tributary of nearby Lake Creek.



Figure 9 Photo of the Original Sand Filter Basin

The drainage area consists of residential streets and one segment of a 4-lane boulevard, Anderson Mill Road. The average traffic count is approximately 18,000 vehicles per day (CAMPO 2005). Driscoll et al. (1990) suggests that a count of 30,000 vehicles per day can be used to distinguish urban traffic from non-urban traffic.

### **3.5 Pond 3 Modifications**

Conversion of the Pond 3 BMP required modifications to the existing sand filter basin and the outlet structure between the detention basin and the filter basin. A valve controlling discharge from the detention basin and a control circuit for the valve was developed to operate the valve based on storm events and water level in the detention basin.

#### **3.5.1 Sand Filter Media Removal**

The filter sand and the perforated underdrain were removed from the filtration basin (Figure 10). The sand filter modifications were made by TxDOT through a subcontractor. The outflow from the extended detention basin was allowed to flow over the exposed clay liner of the basin to the outlet pipe. Grass began to grow in the filtration



basin as the study progressed. Water treated in the extended detention basin in the modified system flowed over the surface of the former filtration basin to the outlet.



Figure 10 Photo of Modified Sand Filter Outlet Modifications

The outlet structure of the extended detention basin was modified to accommodate an automatic controller (Figure 11). The extended detention basin modifications were also made by a subcontractor working for TxDOT. The vertical perforated standpipe and trash screen were removed. A 6-inch (100mm) PVC pipe was inserted through the 300 mm (12 in) outlet pipe and the gate valve. The gap between the 6-inch (100mm) pipe and the 300mm (12 in) pipe was sealed with concrete. A wire fabric trash screen was constructed around the outlet.



Figure 11 Photo of Modified Outlet (Trash Screen and Float Switch)

### **3.6 Automatic Controller Design and Installation**

Many requirements were considered in the design of the controller. The controller must operate unattended in remote locations subjected to harsh environmental conditions. The algorithm for operating the valve requires detection of the storm events and water levels in the basin. In order to design a device to meet all the design goals, a set of design requirements was developed for the controller hardware and the algorithm used to operate the valve.

#### **3.6.1 System Requirements**

The system requirements listed below were used to implement the Controller. The system requirements provide high level guidance for the detailed design of the Controller.

- Power – The controller shall be powered by a self-contained, renewable power source (such as solar power) since electrical power is not always available. A single supply voltage for all components is desirable. .



- Programmability – The controller shall be programmable. It shall be possible to update programs in the field. The detention time and drawdown time shall be adjustable in hours from 0 hours to 72 hours.
- Event sensing – The controller shall be able to sense the beginning of a storm (water filling the basin), and the end of a storm (water has drained from the basin).
- Environment – The controller shall operate in temperatures from 0°C to 55°C, in humidity from 10% to 90% (non-condensing). The controller shall operate during periods of rainfall.
- Safety/Security – The system components shall be locked in an enclosure to prevent accidental contact that could compromise the function of the apparatus or cause injury.
- Components – Component parts of the controller shall be off the shelf, multiple sourced parts where possible.
- Maintenance – The controller shall require minimal periodic maintenance. The controller program shall be field upgradeable. The ability to manually operate the valve shall be provided.
- Reliability – 40,000 hours (4.6 years) or greater.

### **3.6.2 Theory of Operation**

Using the System Requirements, a detailed design was developed. The block diagram of the controller is shown in Figure 12.

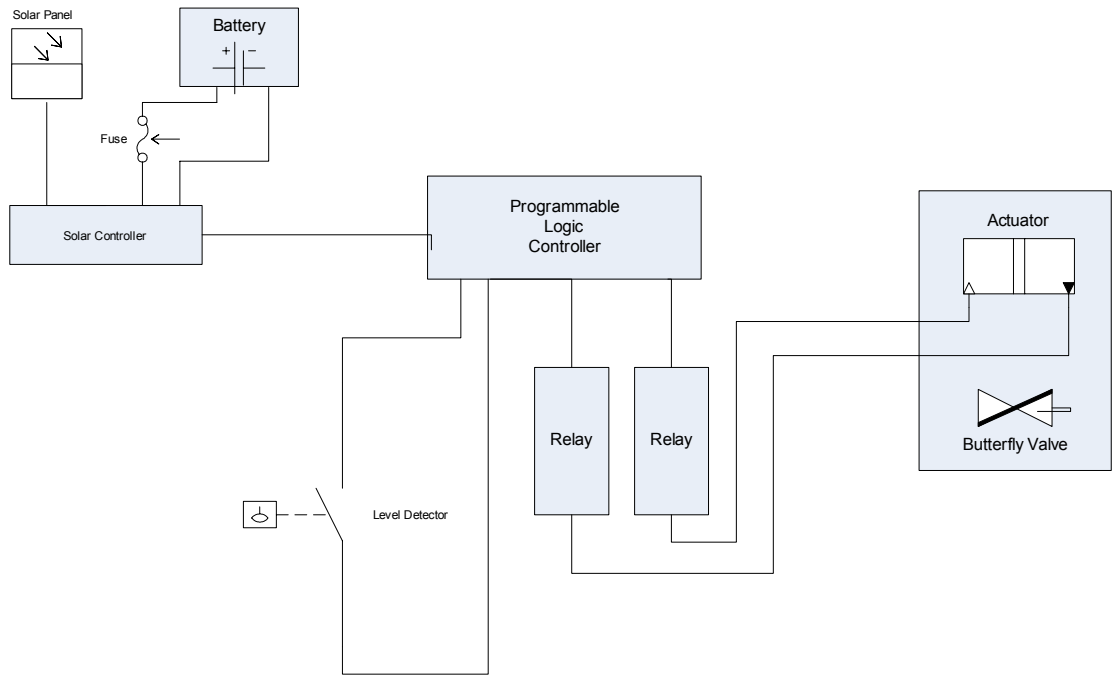

Figure 12 Block Diagram of Controller Circuit

The two key components driving the design of the system are the Valve/Actuator, and the Programmable Logic Controller (PLC). The actuator is the main source of power consumption in the system and thereby drives the sizing of the power supply components. The PLC implements the valve control algorithm, which is the heart of the Controller.

### 3.6.3 Valve/Actuator

The outlet pipe on the extended detention basin is a 6-inch (100mm) PVC pipe. The most economical valve/actuator assembly was determined to be a butterfly valve with a small 12VDC actuator. The valve is a quarter turn valve. The actuator operates the valve between the full open and full closed positions. This valve/actuator combination is not recommended for flow regulation. A mechanical hand crank allows a physical override of the valve position. A pneumatic actuator was considered, but the addition of a separate control system was deemed to add more complexity to the system resulting in a less reliable solution requiring additional maintenance.

The valve selected is a Keystone 6-inch (100mm) butterfly valve. The valve is mated with an EPI-6 12VDC actuator. The actuator was selected based on the pressure head when the extended detention basin is full (approximately 950 mm of water). The

EPI-6 actuator requires an open or close signal of 10 seconds. The actuator has limit switches that detect end of travel and shut off the incoming open or close signal to the actuator once the valve reaches the full open or closed position. Over torque sensors will shut down the actuator in the event of an over torque situation.

### 3.6.4 Power

The controller is implemented as a 12VDC system that runs off a solar charged 12VDC battery. A 12V system was chosen over a 24VDC system to reduce the size of solar panels and batteries needed. The components used in other parts of the system are widely available in 12VDC.

The implemented power circuit consists of a solar panel, solar controller, and battery. The solar controller regulates the solar panel charging current to the battery, and manages the load current as well. The solar regulator also provides an over current shutdown in the case of a low battery condition, or an excessive load condition. The solar panel size and the battery capacity were determined by calculating the power required to operate the Controller for 5 storm events occurring during low light (no battery recharge) conditions. The duration of 5 back to back storm events (filling, detaining, and draining) of the extended detention basin would take approximately 120 hours. The power consumption for 1 storm cycle (24 hours) is shown in Table 7.

Table 7 Controller Power Consumption

Component	Current	Power	Total Power
EPI-6 Actuator	10A @ 12V, 10sec for 90° action	2 x 10A x 12V = 240W	240W x 20sec = 3.3 W-hours
Solar controller	10mA @ 12V	0.12W	0.12W x 24 hours = 2.9 W-hours
Relay	0.9W @ 12V, 10sec for 90° turn	2 x 0.9W = 1.8	0.9W x 20 sec = 0.01 W-hours
PLC	140mA max @12VDC continuous	1.68W	1.68 x 24 hours = 40.3 W-hours
		<b>Total 242.58W</b>	<b>Total 46.5 W-hours</b>

The Controller would use a total of 600W or 232.5 Watt-hours in a 120 hour period. Battery capacity is computed by the formula

$$battery\_capacity(Amp - hours) = \frac{daily\_consumption(Wh / day) \times storage\_day(day)}{battery\_voltage(V) \times 0.7}$$

Using the values for the Controller, a battery capacity of 27.7Amp-hours, or 5.5 Amp-hours/day at 12VDC is needed. Using a battery loss factor of 1.2, the battery capacity is calculated as

$$5.5(\text{Amp} - \text{hours} / \text{day}) \times 1.2 = 6.6(\text{Amp} - \text{hours})$$

The average number of hours of sunlight in a day is 12 hours, which leads to a calculation of 6.6/12 or 0.5A as the value of solar amps needed. The BP SX-10 array provides 0.59A, which matches the power requirements of the controller.

The MK Powered 8GU1 battery was selected as the Controller battery. The MK Powered 8GU1 is a gelled-electrolyte 12V battery with a 36.1Amp-hour capacity, well above the 6.6 Amp-hour capacities required.

### **3.6.5 Programmable Logic Controller**

The programmable Logic Controller (PLC) selected is the IDEC FL1C-H12RCE. It is a 12V controller that has 12 inputs and 4 relay outputs. The PLC is programmed from a Windows based programming interface which downloads the program to the PLC. There are a variety of components in the IDEC FLxx family – including components that have additional outputs, and LCD and switch front panels (IDEC, 2001).

One of the key characteristics of the FL1C is the ability to program large timer intervals – over 72 hours. The FL1C can also implement the short (10 second) pulses needed to operate the actuator.

### **3.6.6 Sensor**

The level sensor selected is a float switch from Anchor Scientific. The sensor is a snap-action switch activated by a steel ball rolling back and forth within a switching tube in a plastic housing. The maximum differential between on and off is approximately 3.5 inches. The switch is mercury free. The 3.5 inch differential results in approximately 3 inches of water remaining in the basin once the sensor signals an empty condition.

### **3.6.7 Relays**

Although the PLC outputs are relay outputs, external relays are used to isolate the outputs of the PLC. The relays switch power to the actuator, and carry a maximum of 10A. The relays have LED indicators that light when the relay is energized. They also have manual activation switches. These switches should not be used as they can cause a conflict with the PLC relay control signals.

### 3.6.8 Enclosure

The enclosure selected for the Controller is a BBG-1 from Southwest Photovoltaic. The enclosure is a brushed aluminum box with screened ventilation louvers. The enclosure can be locked for security and safety purposes. The enclosure is 15.75 inches wide, 9.75 inches deep, and 11.75 inches in height. The enclosure, along with the solar panel, is mounted on a 2 inch diameter pole.

### 3.6.9 Implementation

The final implementation of the controller is shown in Figure 13. The battery partially obscures the view of the two relays.

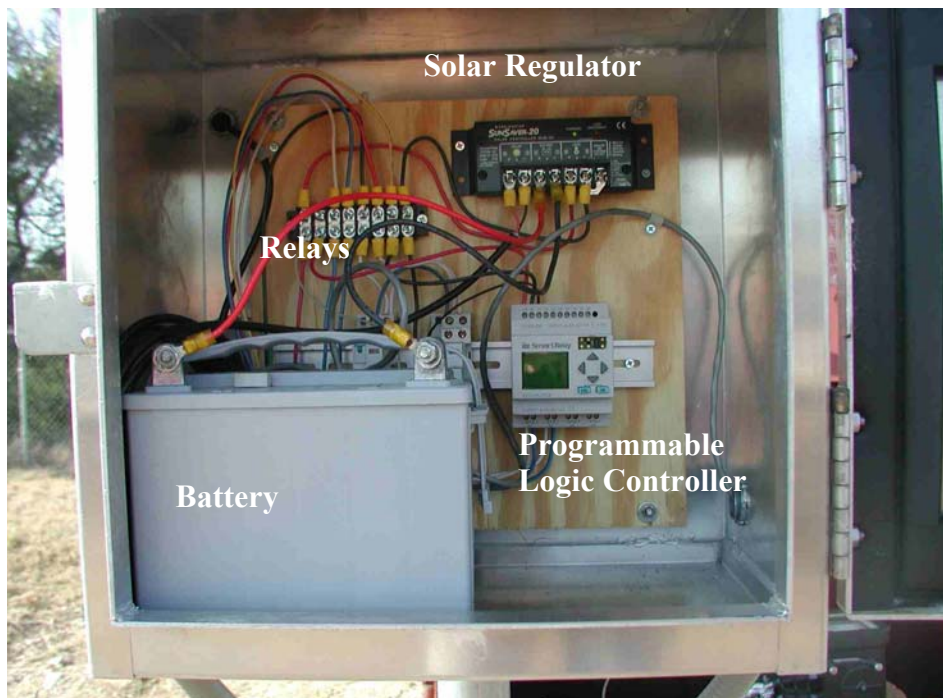
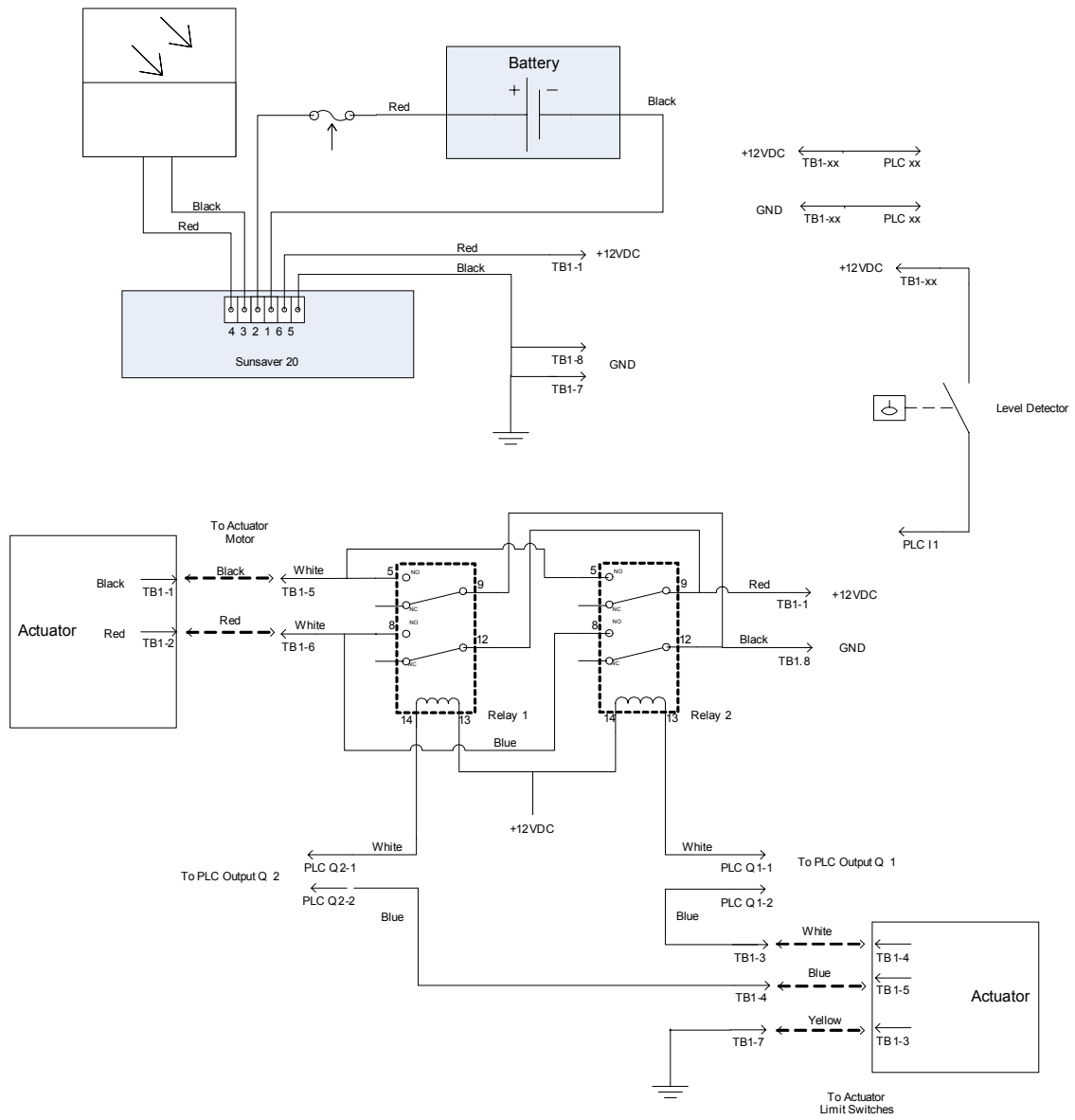

Figure 13 Photo of Controller as Implemented

The schematic of the controller is shown in Figure 14. A costed bill of material is provided in Appendix B. The total cost for the prototype was approximately \$1,550.



Updated 9/17/2005

Figure 14 Controller Schematic

### 3.6.10 Programming

The PLC program was designed by considering the use cases, or operational scenarios as detailed in Figure 15.

- Use Case 1: A single rain event fills the extended detention basin. The basin holds the diverted stormwater for the detention time and then releases the water.
- Use Case 2: A single rain event occurs, but does not completely fill the extended detention basin. The basin holds the water for the detention period, and then releases it.
- Use Case 3: A single rain event fills the extended detention basin with approximately 3 inches of water – under the trip point of the level sensor. The level sensor does not trip. The captured water is held until it infiltrates/evaporates or is joined by stormwater from a subsequent storm.
- Use Case 4: Begins the same as Use Case 1. During the drawdown period, one or more additional rain events occur causing additional water to enter the extended detention basin. The valve remains open and the additional water volume is drained.
- Use Case 5: Begins the same as Use Case 2. During the drawdown period, one or more additional rain events can occur causing additional water to enter the basin. The valve remains open and the additional water volume is drained.

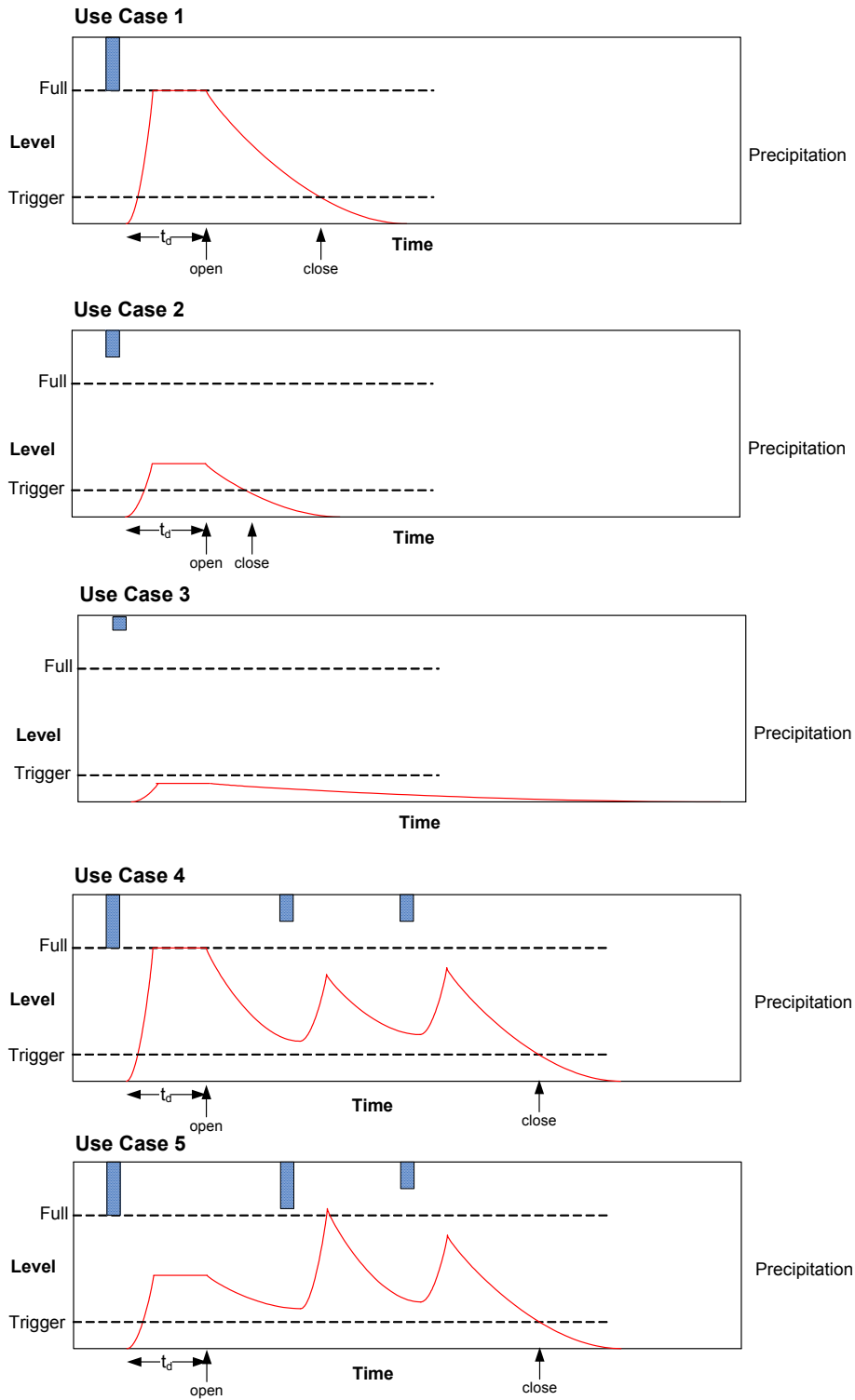

Figure 15 PLC Program Use Cases



Review of the use cases show that the Controller triggers the detention time timer whenever the water level rises through the trigger point. The Controller detects the water level is lower than the trigger level and, after a delay to allow the remaining water to drain, closes the valve and waits for the next storm. The drawdown time is independent of the time required for the basin to drain since it depends on water level.

Additionally, use cases 4 and 5 illustrate the fate of water captured by the extended detention basin in storms that occur after an initial storm has triggered the controller, but before the basin has drained to a level below the trigger point. This water will be detained by a time determined by the drawdown time due to the orifice size.

The program consists of a power-up circuit, a test circuit, and a main circuit. A flowchart for the program is shown in Figure 16. The power-up circuit sends a valve close signal to the actuator to insure that the valve is closed prior to arming the main circuit. This is necessary to synchronize the valve and the controller logic.

The main circuit is a state machine consisting of 3 states. In the Idle State, the valve is closed and the state machine waits for the level sensor to indicate there is water in the extended detention basin to move to the Detention State. In the Detention State, the detention timer is started. Once the end of the detention time is reached, an open valve signal is sent to the actuator. The state machine then enters the Drawdown State, where it waits for the level sensor to indicate the extended detention basin is empty. Once the extended detention basin is empty, a delay of 2 hours is started to allow the basin to completely drain, and then a close signal is sent to the actuator to close the valve and the state machine returns to the Idle State.

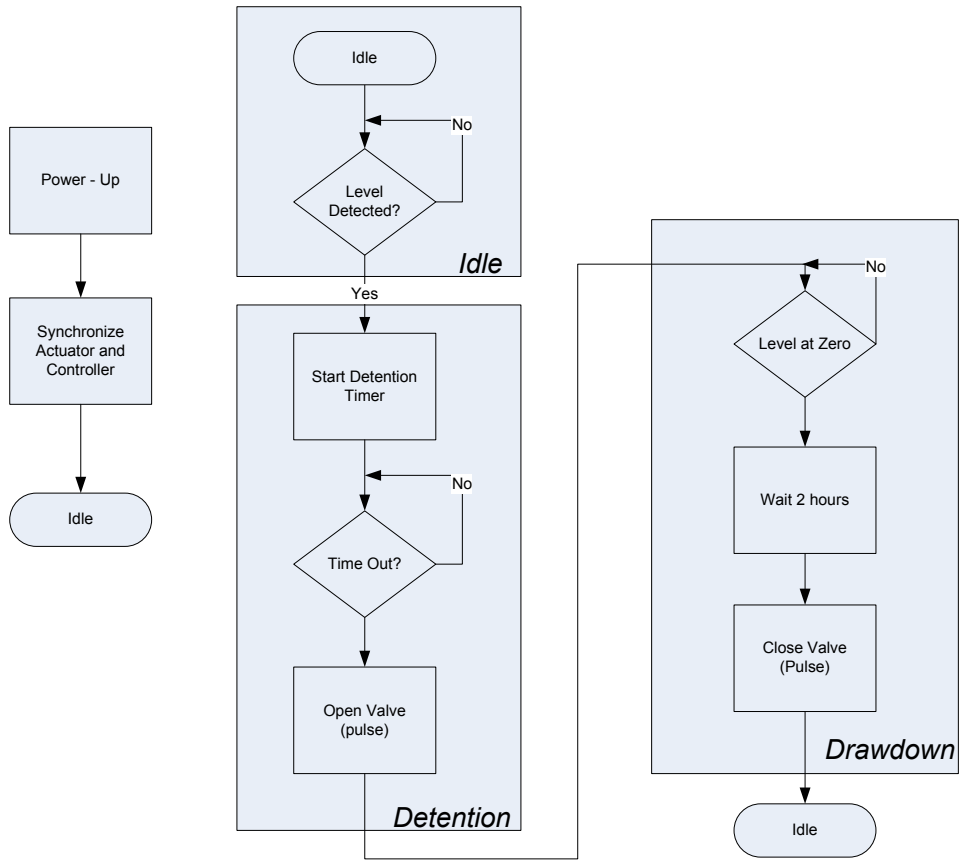

Figure 16 PLC Program Flow Chart

The test circuit provides manual open/close control of the valve through optional toggle switches. The toggle switch position is sensed by the circuit, and the appropriate open or close signal is sent to the actuator.

Lockouts are implemented on the open and close valve circuits to prevent simultaneous open/close signals from being sent to the actuator. A detailed view of the PLC program is shown in Figure 17.

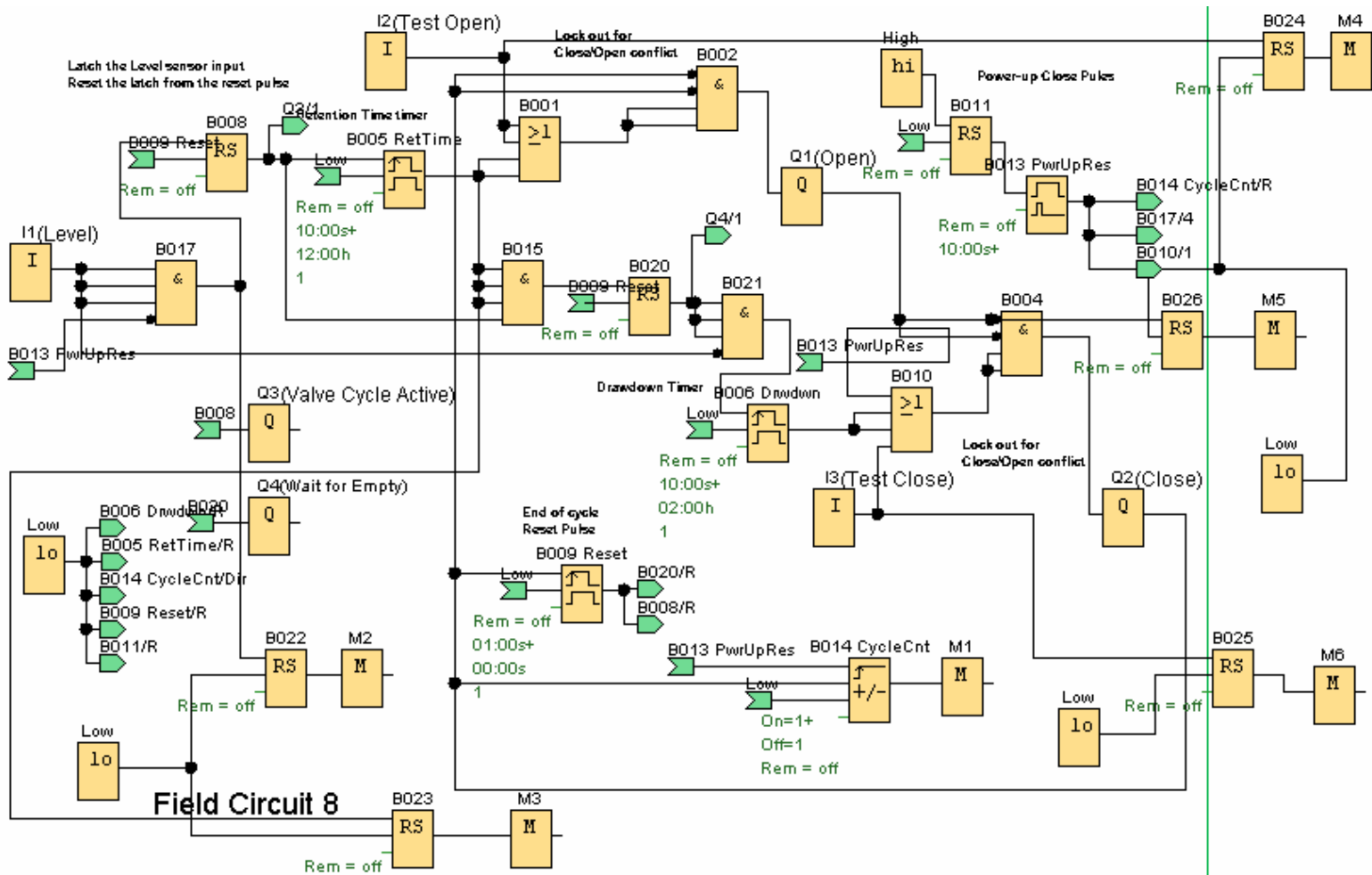

Figure 17 Detailed view of PLC Control Program

The level sensor is input from block I1 and feeds an AND module (B017) which in turn drives the “Set” input of a latching relay (B008). The latching relay is the start signal for the detention timer (B005). The detention timer is triggered by a rising edge, and starts a 12 hour detention time followed by a 10 second open pulse.

The open pulse (output of B005) feeds the Close/Open lockout circuit and also the drawdown pulse circuit. The Close/Open circuit drives the Open output (Q1) based on an OR condition (B001) from the open pulse (output of B005) and the test switch input (I2). The Or of these 2 signals is routed through the And gate (B002) which blocks the generation of an Open output if a Close signal is active. As an input to the drawdown logic, the open pulse (output of B005) also drives the drawdown circuit by feeding the AND block (B0015) that arms the drawdown timer by creating a latch input for latching relay (B020) that is the AND of the latched level sensor and the Open pulse. The latching relay output (B020) is further qualified with the level sensor (I1) to trigger the drawdown pulser (B006). The drawdown pulser generates a 10-second pulse that feeds a lockout circuit. The lockout circuit forms an OR (B010) of the Close pulse with the close test switch (I3). The OR’ed signal is then blocked by an active Open signal in AND block (B004), which drives Close output (Q2).

The power-up circuit synchronizes the valve position with the circuit state machine. It is initiated by setting a reset latch (B011). The reset latch is set once at power up and never reset. The reset latch output triggers a pulser (B013) that creates a 10-second valve close pulse that is an input to the Close OR block (B010) and is also used to blank a potential level sensor input during the synchronizing function.

An end of cycle reset pulse generated by B009 is initiated by the rising edge of the Close pulse (O3). Optional indicator signals are output on outputs O3 and O4. Output O3 indicates an active valve cycle is in progress. Output O4 indicates the detention time has expired and the circuit is waiting for the level sensor to indicate an empty condition.

### **3.6.11 Installation**

The controller and solar panel were mounted on a 2-inch metal pole located on the weir between the extended detention basin and the filtration basin. The solar panel was set at a fixed angle of 56 degrees facing south. This positioning optimizes the panels for the winter midday position of the sun. Repositioning of the solar panel in the summer months would generate more energy, however sufficient energy is generated with the winter positioning (Landau, 2001). The metal pipe was secured in the ground with concrete. Buried conduit was used to house the wiring from the controller to the controller.

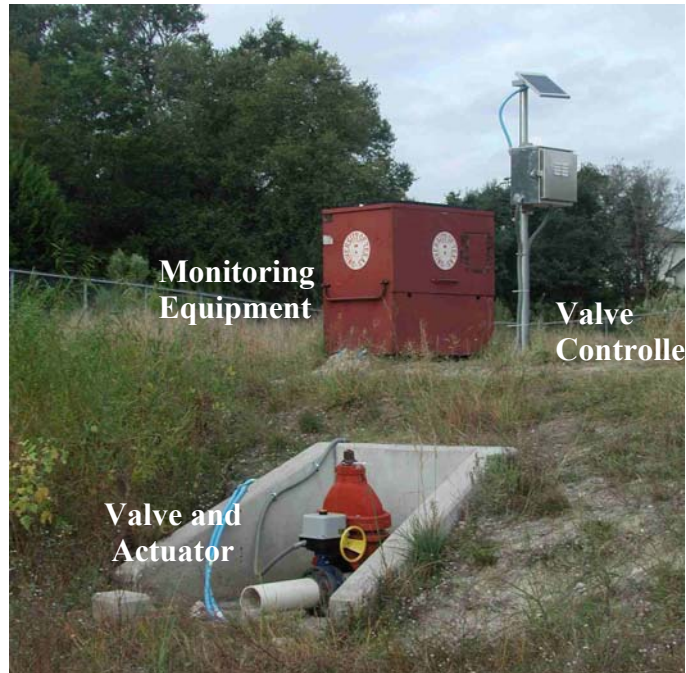

Figure 18 Controller placement

The actuator and valve were installed on the 6-inch (100mm) PVC pipe as shown in Figure 19.



Figure 19 Valve and Actuator

The float switch was installed on the concrete apron in near the outlet of the extended detention basin (Figure 20). The wiring from the float switch to the actuator was housed in buried conduit.



Figure 20 Float Switch

### **3.7 Monitoring Equipment**

#### **3.7.1 Inflow Sampler**

Inflow sampling is performed using an ISCO<sup>®</sup> 4150 area velocity flow meter, an ISCO<sup>®</sup> 3700 Sampler and an ISCO<sup>®</sup> 674 tipping-bucket rain gage. The sampling equipment is located in a security box located adjacent to the extended detention basin inlet. The equipment is powered by a solar panel charged 12-VDC marine battery. The ISCO<sup>®</sup> 4150 flow meter was selected over a bubbler flow meter due to backwater effects caused by the basin water surface. The sensor uses a pressure transducer to measure water depth, and a Doppler sensor to measure the velocity of suspended particles in the flow. The ISCO<sup>®</sup> 4150's low profile area velocity sensor is mounted on a lexan plate and fastened to the inlet box culvert floor. The sensor is mounted slightly off center in



the culvert due to the presence of sand and gravel sediments deposited during flow into the extended detention basin (Figure 21).

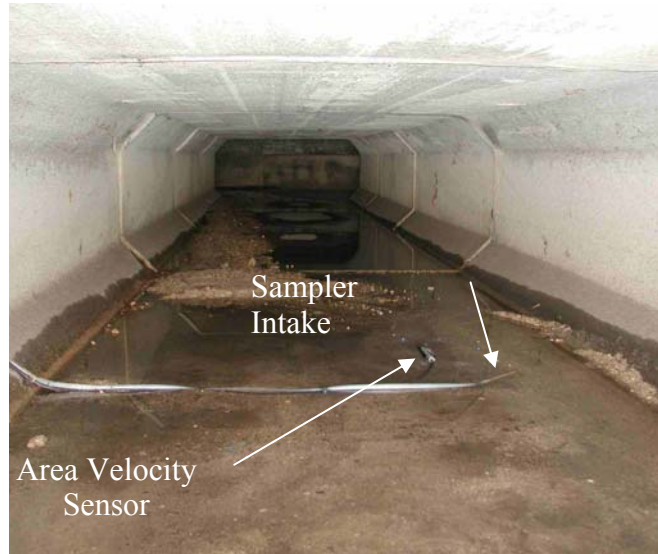

Figure 21 Inlet Sensor and Sampler Intake Placement



Figure 22 Inflow Sampler and Flow Meter

Sampling the inflow to the extended detention basin requires a composite sample to be taken through the time interval that water enters the basin. The capture volume of the storm, the size of the sampling container, and the minimum sample size required for analysis are the constraining parameters determining the sampler programming.

The intake of the ISCO<sup>®</sup> 3700 sampler is fastened to the floor of the box culvert near the area velocity sensor as shown in Figure 21.

Composite samples of storm inflow are stored in a 9.4 L bottle in the sampler. The ISCO<sup>®</sup> 3700 sampler is triggered by the 4150 flow meter when rainfall of 0.5mm occurs in a 15 minute period and a water level of 5 mm is detected. Flow paced sampling is used with flow intervals of 22 m<sup>3</sup> and sample aliquots of 220 ml taken at each interval. A minimum sample size of 1 L is required for constituent testing. The minimum storm size of 10 mm of precipitation can be sampled using these settings. The settings were selected to insure a maximum of 42 aliquots would be spaced over the entire volume required to fill the extended detention basin, yielding a total sample volume of 9.2 L.

### 3.7.2 Outflow Sampler

Sampling the outflow presents similar but slightly different constraints from the inflow sampling. Ideally, a flow paced composite sample would be taken of the effluent in a similar fashion to the influent. The effluent exits the extended detention basin through a 6-inch (100mm) pipe that flows full during discharge. The flow meters available for the study were designed to operate in open channels and could not accurately measure the flow in the outlet. A time based sampling program was developed using the drawdown time of the basin and a time-based sampling algorithm recommended by ISCO. The timing sequence was triggered by the detection of water level in the outlet pipe by the flow meter.

The drawdown time of the basin was estimated using the orifice equation for a 6-inch orifice. A drawdown time of approximately 13 hours was calculated for a full water quality volume and the corresponding water height in Pond 3.

$$Q = C_D A_0 \sqrt{2gh(t)}$$

$Q$  = flow rate [ $L^3 / T$ ]  
 $C_D$  = orifice coefficient  
 $A_0$  = surface area [ $L^2$ ]  
 $g$  = acceleration due to gravity, [ $L/T^2$ ]  
 $h(t)$  = depth of water, [ $L$ ]



The orifice equation was also used to develop time based pacing for the outflow sampler. Once the valve opens to release water from the detention basin the outflow is a function only of the height in the basin. A timing sequence based on flow rates was calculated and the resulting time pacing table is presented in Table 8.

Table 8 Time Based Sampling Program for Outflow Sampler.

Sample Number	$\Delta t$	Total Time (min)	Total Time (hour)	Sample Number	$\Delta t$	Total Time (min)	Total Time (hour)
trigger	0	0	0.0	22	13	246	4.1
1	8	8	0.1	23	13	259	4.3
2	10	18	0.3	24	15	274	4.6
3	10	28	0.5	25	15	289	4.8
4	10	38	0.6	26	15	304	5.1
5	10	48	0.8	27	15	319	5.3
6	10	58	1.0	28	16	335	5.6
7	10	68	1.1	29	17	352	5.9
8	10	78	1.3	30	17	369	6.2
9	11	89	1.5	31	17	386	6.4
10	11	100	1.7	32	19	405	6.8
11	11	111	1.9	33	20	425	7.1
12	12	123	2.1	34	20	445	7.4
13	12	135	2.3	35	22	467	7.8
14	12	147	2.5	36	25	492	8.2
15	12	159	2.7	37	25	517	8.6
16	12	171	2.9	38	28	545	9.1
17	12	183	3.1	39	32	577	9.6
18	12	195	3.3	40	40	617	10.3
19	12	207	3.5	41	49	666	11.1
20	13	220	3.7	42	106	772	12.9
21	13	233	3.9				



Figure 23 Outlet Sensor Placement

An attempt was made to sample flow and level in the pipe an empirical formula suggested by ISCO known as the California Pipe Method (ISCO, 2001). This method is based on an empirical formula that is used to determine flow rate from the open end of a partially filled pipe discharging freely into the air. This method can achieve accuracies of 10% under optimal conditions. Optimal conditions were not present in the modified outlet since the pipe flowed full and the discharge did not flow free. The flow meter reliably detected the initiation of flow once the valve opened, but did not reliably measure flow and level in the pipe.



Figure 24 Outflow Sampler and Flow Meter

### 3.8 Analytical Procedure

Runoff samples were collected as soon as possible after a storm occurred. Due to the timing of the inflow and outflow sampling program sequences, inflow samples were available 12 hours before the outflow samples. Samples were analyzed by two laboratories. Primary analysis was performed by the Environmental Laboratory Services, a division of the Lower Colorado River Authority (LCRA). For storms that generated sufficient sample volume, secondary analysis was performed at The University of Texas at Austin. When there was sufficient volume, samples were split to provide samples to both laboratories. The Environmental Laboratory Services required 2 L samples to perform the required analysis. A total of 1 L was typically reserved for SSC analysis at The University of Texas at Austin laboratory, although approximately 100 mL was the minimum required.

Samples were split using a Dekaport Cone Sample Splitter™. The Dekaport splitter divides a sample into ten equal sub-samples. The full sample volume from storms that filled the extended detention basin was approximately 9L. Thus the sub-samples were 0.9 L in volume. In the case of storms that produced smaller sample volumes, sub-samples were smaller and the sub-samples were combined to create the appropriate sub-sample volume for analysis.

Samples were delivered immediately to the Environmental Laboratory Services when possible. Samples were stored in a 4° C refrigerator if the labs were not open when the samples were collected. The Environmental Laboratory Services analyzed the samples for conventional constituents found in urban runoff – total suspended solids (TSS), dissolved and suspended metals, phosphorus, nitrogen, and chemical oxygen demand (COD). The testing parameters and their corresponding Practical Quantification (PQ) Limits are detailed in Table 9 (note that metals concentrations are listed in µg/L).

Table 9 Parameters for Analysis by Environmental Laboratory Services

Parameter	Units	PQ Limit	Method
Total Copper	µg/L	1.02	E200.8
Total Lead	µg/L	1.02	E200.8
Total Zinc	µg/L	4.08	E200.8
Dissolved Copper	µg/L	2.00	E200.8
Dissolved Lead	µg/L	1.00	E200.8
Dissolved Zinc	µg/L	5.00	E200.8
Chemical Oxygen Demand	mg/L	7	E410.4
Nitrogen, Nitrate & Nitrite	mg/L	0.0200	E300
Phosphorus, Dissolved (As P)	mg/L	0.020	E365.4
Phosphorus, Total (As P)	mg/L	0.020	E365.4
Nitrogen, Kjeldahl, Total	mg/L	0.020	E351.2
TSS (Residue, Non-filterable)	mg/L	1.0	E160.2

## CHAPTER 4 RESULTS

### 4.1 Preliminary Monitoring

Preliminary monitoring of the study site took place during a two-month period in February and March of 2005. During this period, Pond 3 was still configured as an Austin sand filter. The gate valve between the two basins of the sand filter was opened and closed manually to simulate operation of the proposed automatic controller. The valve was left closed prior to a storm. The valve was opened and a grab sample was taken after stormwater filled the sedimentation basin. This process was repeated at various retention times to estimate the TSS levels in the influent and form an estimate of the required retention time to be used in the automated controller. Grab samples were taken holding a sampling container in the discharge from the sedimentation basin approximately 3 minutes after the gate valve was opened. The preliminary data are shown in Table 10.

Table 10 Preliminary Sampling Results

Storm	Rainfall			Sample			
	Date	Depth (mm)	Time	Time	Level (mm)	Detention time (h)	TSS (mg/L)
1	13-Feb-05	4.1	5am	8:30am	171	3.3	92
1				2:00pm		9	25
2	24-Feb-05	10	6:00am	6:00pm	235	12	16
3	2-Mar-05	25.4	10:00am	7:00pm	787.4	9	44
4	20-Mar-05	0.3	3:00pm	7:00pm	133.35	4	81
5	26-Mar-05	*	11:00pm	8:00am	711.2	30	18

\* rainfall data not available

The effluent TSS concentration appeared to remain constant for retention times of 12 hours or longer. Therefore, a retention time of 12 hours was selected as the setting for the automatic controller.

### 4.2 Sampling Issues

Several equipment issues were encountered during the study. The various issues and their respective resolutions are presented in this section.

The Doppler sensor of the ISCO<sup>®</sup> 4150 flow meter and the intake of the ISCO<sup>®</sup> 3700 inflow sampler were initially placed in the center of the box culvert at the inlet to

the detention basin. A large amount of sediment consisting of small gravel and sand was deposited in the culvert during each storm. The sediment covered the sensor and the intake in many storms, causing errors in the velocity readings. The sensor and intake were relocated just off center to prevent the condition from reoccurring.

An ISCO<sup>®</sup> 4150 flow meter was used to monitor the inflow to the basin at the beginning of the study. The ISCO<sup>®</sup> 4150 flow meter does not have a built-in printer or display and is completely operated using a laptop computer. Incorrect velocities were logged during the first few storms that were monitored, particularly when the water level in the culvert was low. The erroneous velocity measurements caused calculation of incorrect flow values which in turn caused incorrect flow pacing to be calculated. Therefore the ISCO<sup>®</sup> 4150 was replaced with an ISCO<sup>®</sup> 4250 area velocity flow meter on November 25, 2005. The ISCO<sup>®</sup> 4250 flow meter is an older model that has an operator panel, a display, and a printer. The ISCO<sup>®</sup> 4250 measured and recorded velocity and flow data without the errors that affected the data reported with the ISCO<sup>®</sup> 4150. The ISCO<sup>®</sup> 4150 is designed as a data logger and powers down between sampling events. Therefore transient events are not recorded, particularly when the water level is low. The ISCO<sup>®</sup> 4250 remains powered up and does not have the same issues with transient events.

The observed rainfall measurements were lower than unofficial rain data from gages located near the study site during the start of the study period. The observed low rainfall values were initially attributed to spatial variations in rainfall which is common in the summer months in central Texas. Spider webs impeded the motion of the tipping bucket after the August 4 storm. The rain gage was replaced in December 2005. The rain gage was blocked on one occasion by bird droppings, resulting in partial blockage of rainfall through the funnel. The resulting low rainfall readings prevented the sampler from being triggered. A plastic rain gage was attached to a fence near the tipping bucket sampler on November 24, 2005. Total depth of rainfall for a storm was measured with the plastic gage as a point of comparison with the ISCO<sup>®</sup> 674 rain gage. Sufficient data are not available to correlate the plastic rain gage data with the ISCO<sup>®</sup> 674 rain gage data.

The nearby tributary of Lake Creek was observed to back up into the sand filter basin of Pond 3 during two storms in March 2006. The level detected by the outflow sampler in both storms was sufficient to trigger the outflow sampler and foul sampling bottles. The bottles were replaced after the basin drained and before the automatic controller released water from the first basin.

### 4.3 Storm Characteristics

The modified basin was monitored from July 27, 2005 to May 17, 2006. The normal rainfall in Austin Texas during the time period corresponding to the study period is approximately 560 mm as measured at Camp Mabry in Austin Texas. The total rainfall in Austin during the study period was 450 mm. March and May rainfall totaled 191 mm and 131 mm respectively. The rainfall data indicates that the central Texas area experienced drought conditions during the study period. A hyetograph of rainfall during the study period compiled using data from the ISCO rain gage at the study site are presented in Figure 25.

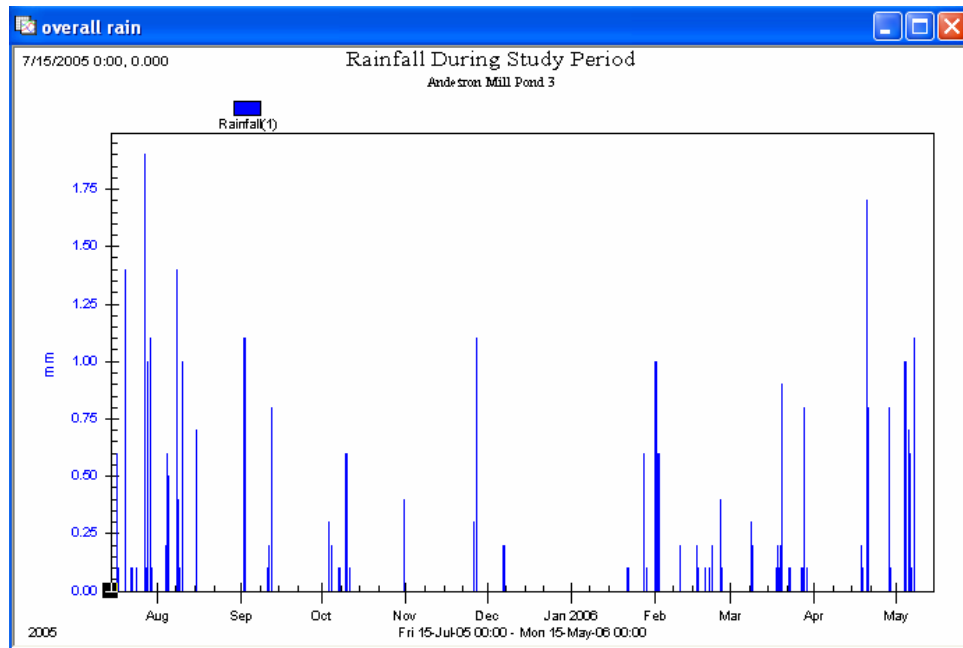

Figure 25 Rainfall During Study Period

A total of 13 storms were sampled during the study period. The storm characteristics are summarized in Table 11. Storms 6 through 10 were sampled using the ISCO<sup>®</sup> 4150 flow meter. Subsequent storms were sampled using the ISCO<sup>®</sup> 4250 flow meter (refer to Section 3.7.1 for a discussion of the two flow meters). The ISCO<sup>®</sup> 674 rain gage was replaced with another ISCO<sup>®</sup> 674 rain gage after storm ten (October 31, 2005).

Table 11 Storm Characterization

Storm	Date	Precipitation (mm)				Max Depth (mm)			Basin	
		ISCO Gage	N. Austin	Gage	Duration (h)	2-min	1-hr	4-hr	Volume (m <sup>3</sup> )	Stage (mm)
6	28-Jul-05	25.8	na	na	3.3	1.9	8.8	-	1637	846
7	4-Aug-05	10.5	81	na	17.1	0.6	5	7	616*	480
8	15-Aug-05	2.5	0	na	0.2	0.7	2.5	2.5	266	233
9	10-Oct-05	7.2	19.3	na	9.4	0.6	4	6.3	445	352
10	31-Oct-05	2.3	23.9	na	1	0.4	2.2	2.3	225	180
11	26-Nov-05	2.7	12.2	8	2.5	0.3	1.7	2.7	351	141
12	28-Jan-06	15.6	1	47	7.6	0.6	8.8	13.9	1235	773
13	25-Feb-06	4.0	0	12.5	15.2	0.4	1.7	3.7	455	259
14	8-Mar-06	3.0	na	na	4.5	0.3	1.5	0.6	393	172
15	18-Mar-06	16.0	na	46	41.3	0.9	10.1	3.25	997	782
16	20-Apr-06	15.0	na	44	18	0.8	10.4	3.5	1392	778
17	29-Apr-06	7.0	na	22.5	3.1	24	6	1.8	717	476
18	4-May-06	12.5	na	38	2.4	30	11	3.1	409	762

\*Estimated from stage

The plastic rain gage data were correlated with both the stage in the detention basin and the ISCO<sup>®</sup> rain gage data for the six storms where common data were available (storms 11 through 16). The plastic rain gage was disturbed during storm 14, and no data was recorded. Rainfall depths within a 3 mm range were recorded during three of the storms (storms 12, 15, and 16). These three storms completely filled the basin and overflowed the weir in the storm sewer so the rain depth and basin volume could not be correlated. The remaining two storms did not provide enough data to establish a rainfall-stage trend.

#### 4.4 Controller Operation

The controller was installed and activated August 17, 2005. A manufacturing issue with the actuator was discovered during the installation and the actuator was returned to Tyco for repair. The repaired actuator was reinstalled on October 3, 2005 and the controller was activated. A programming error was discovered during the October 10, 2005 storm. The valve was operated manually and the influent and effluent were sampled properly. The controller program was revised on October 27, 2005 and was in operation for the entire study period with only one interruption in service.

The interruption in service took place on March 6, 2006. The valve was manually opened as a demonstration of the hand crank on the actuator. The controller was reset to close the valve. The actuator was observed at the time it was scheduled to open after the storm on March 8, 2006. The relays in the controller were heard to activate, and a motor binding noise was heard from the actuator. The hand crank was used to “break” the valve loose and the controller and actuator have operated properly since.

The storms monitored during the study period and the resulting controller operation were evaluated and compared to the controller’s use case scenarios described in section 3.6.10. The controller was operational during eight storms as shown in Table 12. A programming error occurred during one of the eight storms. The monitored storms

tested four of the possible use cases in the design specifications. Use Case 3 is not included in the monitored storms because the condition of a small rainfall depth does not trigger the controller and the runoff is not sampled. The Flowlink<sup>®</sup> data for a storm described by Use Case 3 is shown in Figure 26. The Flowlink<sup>®</sup> graph for a storm described by Use Case 1 is shown in Graphs of the storms listed in Table 12 can be found in Appendix A.

Table 12 Storms Categorized by Use Case

7					
					N
	15-Aug-05	0.2	233	2	No
9	10-Oct-05	9.4	352	4	Yes - Error
10	31-Oct-05	1	180	2	Yes
11	26-Nov-05	2.5	141	5	Yes
12	28-Jan-06	7.6	773	5	Yes
13	25-Feb-06	15.2	259	4	Yes
14	8-Mar-06	4.5	172	1	Yes
15	18-Mar-06	41.3	782	5	Yes
16	20-Apr-06	18	778	5	Yes
17	29-Apr-06	3.1	476	2	Yes
18	8-May-06	2.4	762	1	Yes

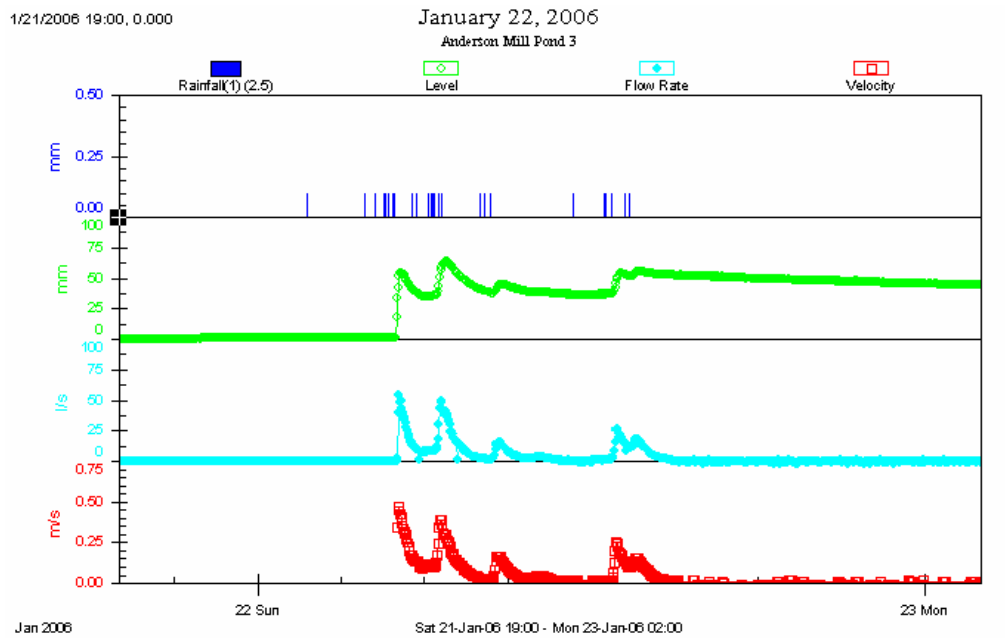

Figure 26 Example of Use Case 3 Storm



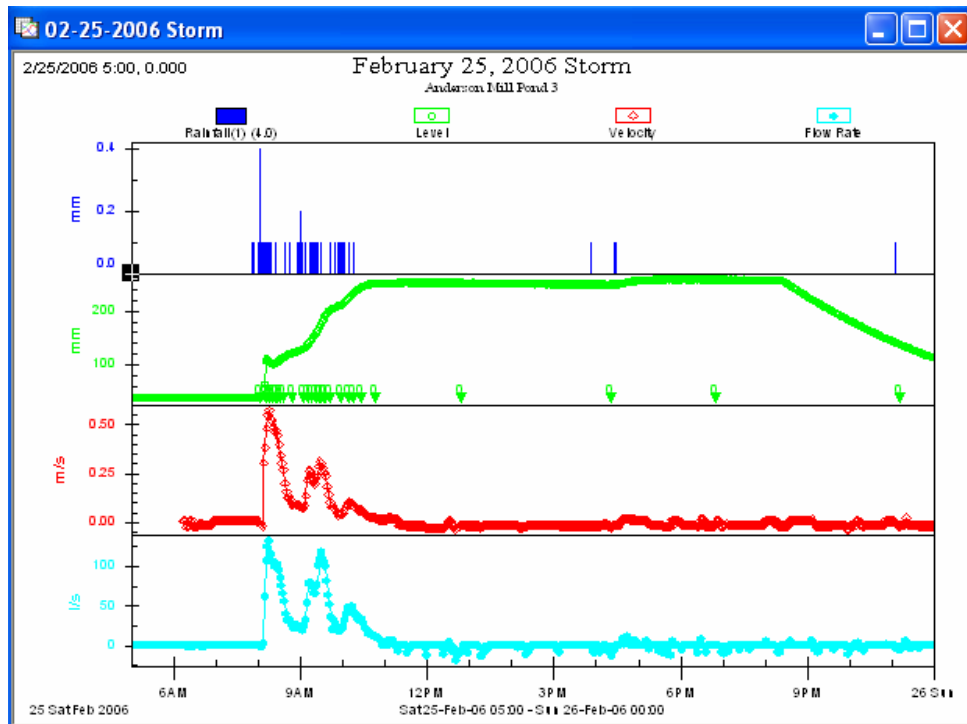

Figure 27. Example of Use Case 1 Storm

## 4.5 Monitoring Results

The data collected from the monitored storms are presented in Table 13. Data are organized by storm event, the constituent tested and detection limit values for each constituent. The LCRA report indicated a “No Detect” condition in the event that a constituent concentration was below the detection limit. The detection limit value was substituted for “No Detect” conditions for this analysis giving a conservative assessment of removal efficiencies and effluent concentrations in the study.

Table 13 Pond 3 Data

**Pond 3 Inflow Data**

Storm	Date	Type	Notes	TSS (mg/L)	Dissolved			Total			COD (mg/L)	Total N (mg/L)	disolved P (mg/L)	Total P (mg/L)
					Cu (µg/L)	Pb (µg/L)	Z (µg/L)	Cu (µg/L)	Pb (µg/L)	Z (µg/L)				
	detection limits			1.0	1.02	1.02	4.08	2.00	1.00	5.00	7	0.0200	0.020	0.020
6	7/28/2005	Composite		34										
7	8/4/2005	Composite	split at UT	40	2.00	1.02	19.6	11.60	2.40	36.4	34	0.5031	0.052	0.117
8	8/16/2005	Composite	split at LCRA	27	2.89	1.02	25.2	6.14	2.09	22.3	51	0.2808	0.081	0.167
9	10/10/2005	Composite	split at UT	57	1.89	1.02	15.4	8.24	4.17	49.4	36	0.3578	0.020	0.101
10	10/31/2005	Composite	not enough to split	56	5.53	1.02	21.0	10.0	2.98	48.9	65	0.7950	0.177	0.226
11	11/26/2005	Composite	not enough to split	75	3.53	1.02	11.8	9.05	1.78	51.2	59	0.3558	0.18	0.227
12	1/28/2006	Composite	split at UT	134	2.88	1.02	21.5	12.00	5.39	76.1	59	0.39	0.114	0.252
13	2/25/2006	Composite	split at UT	52	2.91	1.02	16.9	6.18	2.36	37.7	39	0.33	0.020	0.062
14	3/8/2006	Composite	split at UT	127	5.63	1.02	20.0	12.10	4.70	37.7	74	0.74	0.052	0.244
15	3/19/2006	Composite	split at UT	95	2.28	1.02	20.6	5.73	2.91	37.2	35	0.33	0.115	0.186
16	4/20/2006	Composite	split at UT	119	2.39	1.02	4.4	11.80	5.74	60.7	65	0.42	0.521	0.699
17	4/28/2006	Composite	split at UT	57	1.88	1.02	4.7	4.40	1.51	21.1	50	0.36	0.698	0.738
18	5/4/2006	Composite	split at UT	50	2.53	1.02	5.7	4.79	2.09	25.6	40	0.46	0.185	0.3

**Pond 3 Outflow Data**

Storm	Date	Type	Notes	TSS (mg/L)	Dissolved			Total			COD (mg/L)	Total N (mg/L)	disolved P (mg/L)	Total P (mg/L)
					Cu (µg/L)	Pb (µg/L)	Z (µg/L)	Cu (µg/L)	Pb (µg/L)	Z (µg/L)				
	detection limits			1.0	1.02	1.02	4.08	2.00	1.00	5.00	7	0.0200	0.020	0.020
6	7/28/2005	Grab - outflow		8										
7	8/4/2005	Grab - outflow	split at UT	7	2.56	1.02	13.6	2.98	1.00	29.8	18	0.2081	0.020	0.054
8	8/16/2005	Composite	split at LCRA	1.0	2.94	1.02	17.7	3.3	1.00	14.5	30	0.0200	0.067	0.120
9	10/10/2005	Composite	not split	4	2.52	1.02	17.4	2.83	1.00	15.6	23	0.1401	0.020	0.028
10	10/31/2005	Composite	not split	5	7.01	1.02	16.5	8.41	1.00	21.7	55	0.3018	0.187	0.243
11	11/26/2005	Composite	not split	5	5.73	1.02	16.1	6.75	1.00	25.7	62	0.0200	0.282	0.333
12	1/28/2006	Composite	not split	9	2.60	1.02	8.87	2.99	1.00	12.3	28	0.1300	0.082	0.098
13	2/25/2006	Composite	not split	9	3.13	1.02	13.50	3.81	1.00	14.1	28	0.1700	0.020	0.073
14	3/8/2006	Composite	not split	8	5.03	1.02	13.80	5.13	1.00	15.7	62	0.0500	0.058	0.107
15	3/19/2006	Composite	not split	4	1.83	1.02	10.40	2.10	1.00	10.0	16	0.3500	0.053	0.09
16	4/20/2006	Composite	not split	10	2.87	1.02	9.17	3.18	1.00	13.8	32	0.6500	0.184	0.219
17	4/28/2006	Composite	not split	5	2.35	1.02	5.99	2.69	1.00	8.9	27	0.1700	0.073	0.107
18	5/4/2006	Composite	not split	5	1.90	1.02	4.82	2.17	1.00	7.4	19	0.3600	0.020	0.11

A summary of the data in Table 13 is presented in Table 14. In general, influent constituent concentrations at Pond 3 are lower than those reported for many urban sites. Reductions in the concentrations of total metals, COD, nitrate and nitrite, and TKN were also observed, while an increase in dissolved copper and dissolved phosphate occurred.

Table 14 Summary of Sampling Results

Constituent	Units	Limit	Range			
			Influent		Effluent	
			Min	Max	Min	Max
<b>Total Metals</b>						
Copper	µg/L	1.02	4.40	12.10	2.10	8.41
Lead	µg/L	1.02	1.51	5.74	<1.02	<1.02
Zinc	µg/L	4.08	21.10	76.10	7.36	29.80
<b>Dissolved Metals</b>						
Copper	µg/L	2.00	1.88	5.63	1.83	7.01
Lead	µg/L	1.00	<1.00	<1.00	<1.00	<1.00
Zinc	µg/L	5.00	4.35	25.20	4.82	17.70
<b>Chemical Oxygen Demand</b>						
COD	mg/L	7	34	74	16	62
<b>Nitrate and Nitrite</b>						
Nitrogen, Nitrate & Nitrite	mg/L	0.0200	0.28	0.80	<.0200	0.65
<b>Dissolved Phosphate as P</b>						
Phosphorus, Dissolved (As P)	mg/L	0.020	<.020	0.70	<.020	0.28
<b>Total Phosphate as P in Water</b>						
Phosphorus, Total (As P)	mg/L	0.020	0.06	0.74	0.03	0.33
<b>Total Kjeldahl Nitrogen</b>						
Nitrogen, Kjeldahl, Total	mg/L	0.020	0.74	3.91	0.40	2.69
<b>Suspended Solids</b>						
TSS (Residue, Non-filterable)	mg/L	1.0	27	134	1	10

The effectiveness of BMPs in removing constituents can be evaluated by several methods. The evaluation method used for regulatory compliance usually requires determination of overall removal efficiency. A more meaningful characterization of BMP performance is to consider the expected effluent concentration. For example, the effluent concentration for TSS has been shown to be independent of the influent concentration in Austin sand filters (Barrett, 2003).

Strecker et al. (2001) recommend a method of evaluating removal efficiencies based on the premise that concentrations in runoff exhibit a log normal distribution. Using this method, removal efficiencies can be calculated based on log transformed event mean concentrations (EMC) of the influent and effluent referred to as the efficiency ratio method (Barrett, 2003). The efficiency ratio method assumes the data is log-normally distributed. The mean ( $\mu$ ) and the variance ( $s^2$ ) of the log transformed EMCs are calculated as

$$\mu = \frac{\sum x}{n}$$

$$s^2 = \frac{[n\sum x^2 - (\sum x)^2]}{n(n-1)}$$

where x is the natural log of the EMCs; n is the number of data points;  $\sum x$  is the summation of data points. The mean of the EMCs is then calculated as

$$a = e^{(\mu - s^2/2)}$$

The removal efficiency is then calculated as

$$efficiency = \left( \frac{a_{inf} - a_{eff}}{a_{inf}} \right) \times 100$$

where  $a_{inf}$  = average influent concentration;  $a_{eff}$  = average effluent concentration

Comparisons of the mean EMC influent concentration, mean EMC effluent concentration, and the log transformed removal efficiencies at Pond 3, an unlined extended detention basins from a Caltrans study(Caltrans, 2004), and an Austin sand filter study (Barrett, 2003) are presented in Table 15. Note that metals concentrations are in  $\mu/L$ .

Table 15 Influent and Effluent Concentration Comparison

Constituent	Pond 3 Mean EMC			Caltrans Mean EMC			Austin sand filter Mean EMC		
	Influent	Effluent	Removal %	Influent	Effluent	Removal %	Influent	Effluent	Removal %
Total Copper ( $\mu g/L$ )	8.6	3.9	55	53	22	58	21	10	50
Total Lead ( $\mu g/L$ )	3.2	1.0	69	87	24	72	21	3	87
Total Zinc ( $\mu g/L$ )	42.4	15.9	62	418	115	73	236	48	80
Dissolved Copper ( $\mu g/L$ )	3.0	3.4	-11	12	12	0	8.9	8.4	6
Dissolved Lead ( $\mu g/L$ )	1.0	1.0	0	3	2	29	2	<1	39
Dissolved Zinc ( $\mu g/L$ )	16.4	12.5	24	71	60	16	94	36	62
COD (mg/L)	51	33	34	-	-	-	-	-	-
Nitrogen, Nitrate & Nitrite (mg/L)	0.44	0.26	42	1.06	0.98	8	3.72	2.91	22
Dissolved Phosphorus (mg/L)	0.20	0.09	53	0.11	0.14	-22	0.17	0.16	6
Total Phosphorus (mg/L)	0.28	0.14	52	0.52	0.32	39	0.41	0.25	39
Total Kjeldahl Nitrogen (mg/L)	1.59	1.00	37	2.24	1.85	17	3.02	1.48	51
TSS (mg/L)	72	7	91	137	39	72	90	8.6	90

The data presented in Table 15 indicate that influent concentrations at Pond 3 are lower than those at the both the Caltrans sites and the Austin sand filter sites. Similarly the effluent concentrations are lower at Pond 3 than at the other sites. Of particular interest is the mean effluent TSS concentration in Pond 3 compared to the other sites. The effluent TSS concentration at Pond 3 was below 10 mg/L for all monitored storm events. Despite the relatively low influent TSS concentration, the effluent TSS concentration is lower than that of the other BMPs. The removal efficiencies in Table 15 were calculated using the efficiency ratio method. The TSS removal efficiency of 91% in Pond 3 is higher than the 72% TSS removal efficiency of the extended detention basins in the Caltrans report, and comparable to the 90% TSS removal efficiencies in the Austin sand filter study. Both the influent and effluent concentrations of all other constituents in Table 15 are lower in Pond 3 than in the other sites. Removal efficiencies are comparable for total metals, nitrogen and TKN.

The accepted TSS removal efficiency of conventional extended detention basins is 75% (Barrett, 1999) and the lowest effluent TSS concentration achieved is 30 mg/L (WERF, 2005). TSS removal efficiencies of 90% with effluent concentrations as low as 8.6 mg/L have been reported for Austin sand filters (Barrett, 2003). The modified extended detention basin achieves TSS effluent removal efficiency of 91% at an effluent mean concentration of 7 mg/L. The 91% TSS removal efficiency achieved by the modified extended detention basin meets the 90% TSS removal efficiency required in some areas as shown in Table 16.

Table 16 TSS Removal Comparison (from Barrett, 1999)

<b>BMP</b>	<b>TSS Reduction (%)</b>
Retention/Irrigation	100
Constructed Wetlands	93
Wet Basins	93
Modified Ext Detention	91
Sand Filters	89
Vegetated Filter Strips	85
Ext. Detention Basin	75
Grassy Swales	70

## 4.6 Hypothesis Testing

A statistical hypothesis test was performed to determine the statistical significance of the effluent concentration of constituents. The distribution of the influent

concentrations and the effluent concentrations was performed to determine if they were log-normally distributed. Probability plots of TSS influent and effluent concentrations are presented in Figure 28 and Figure 29.

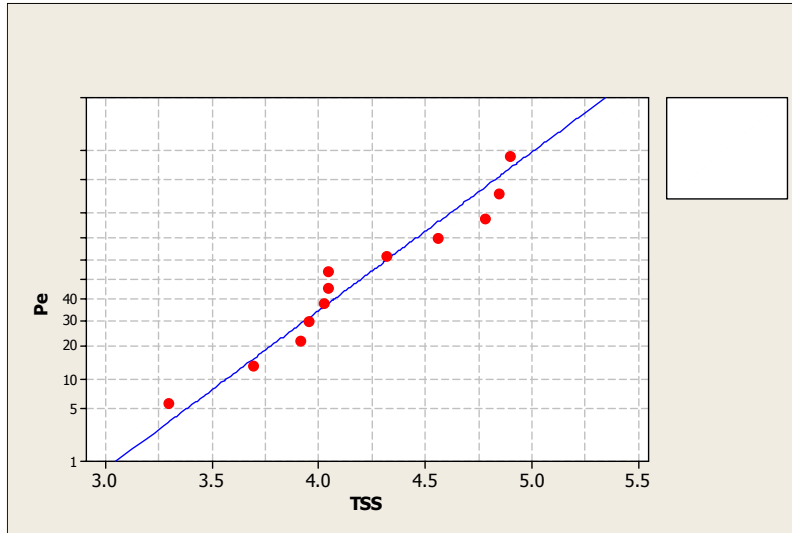

Figure 28 Influent TSS log Normal Probability Plot

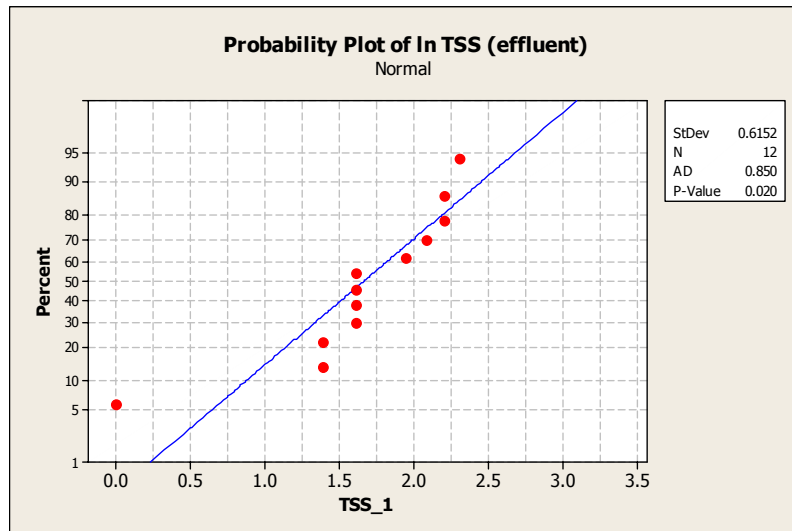

Figure 29 Effluent TSS log Normal Probability Plot

The influent and effluent data follows a log-normal distribution although the sample population is small. Similar results were obtained for the other constituents being analyzed. Paired t-tests can be used to perform hypothesis testing of log-normally

distributed data. A commercially available statistics package, MINITAB<sup>®</sup>, was used to perform the hypothesis testing.

Paired t-tests for each inflow/outflow constituent pair was performed. The results of the hypothesis test are shown in Table 17. The null hypothesis,  $H_0$ , is that there is no difference between the influent and the effluent concentrations of a particular constituent. The alternative hypothesis,  $H_1$ , is that there is a difference. The probability  $p$  that the null hypothesis is true is set to  $p=0.05$  for this analysis. Any  $p$ -value that is relatively small provides evidence that the null hypothesis is false.

Table 17 P-values for Constituents

	N	Paired T	
		T-Value	p-value
<b>Total ICPMS METALS</b>			
Total Copper	12	6.82	> 0.001
Total Lead	12	8.29	> 0.001
Total Zinc	12	7.63	> 0.001
<b>ICPMS DISSOLVED METALS</b>			
Copper	12	-1.29	0.225
Lead	12	na	na
Zinc	12	1.21	0.251
<b>CHEMICAL OXYGEN DEMAND</b>			
COD	12	6.17	> 0.001
<b>Nitrate and Nitrite</b>			
Nitrogen, Nitrate & Nitrite	12	3.53	0.005
<b>DISSOLVED PHOSPHATE AS P IN WATER</b>			
Phosphorus, Dissolved (As P)	12	2.33	0.04
<b>TOTAL PHOSPHATE AS P IN WATER</b>			
Phosphorus, Total (As P)	12	3.62	0.004
<b>TOTAL KJELDAHL NITROGEN</b>			
Nitrogen, Kjeldahl, Total	12	3.31	0.007
<b>SUSPENDED SOLIDS</b>			
Total Suspended Solids (Residue, Non-filterable)	12	18.71	> 0.001

Results presented for the paired t-tests in Table 17 indicate that influent concentrations for dissolved copper, dissolved phosphorus, and total phosphorus are not significantly different from effluent concentrations.

## CHAPTER 5 CONCLUSIONS AND RECOMMENDATIONS

Results of this study demonstrate that the conversion of an extended detention basin to a batch treatment system effectively reduces the loadings of TSS and other constituents in the discharged effluent. Comparisons to conventional extended detention basins indicate that effluent concentrations are lower in the modified basin than in conventional extended detention basins, and are comparable to TSS effluent concentrations in Austin sand filters. Similar results were observed for particulate metals, COD, TKN, and nitrogen. These results were shown to be statistically significant.

The modified extended detention basin achieves TSS effluent removal efficiency of 91% at an effluent mean concentration of 7 mg/L. Effluent concentrations for particulate metals, COD, TKN, and nitrogen were lower than the influent concentrations in the modified extended detention basin. Removal efficiencies for these constituents were comparable to those in conventional extended detention basins and Austin sand filters.

An extended detention basin with improved residence time controls has several advantages over other BMPs. The outlet structure of the modified extended detention basin was not ideal. The outlet was converted by imbedding a 6-inch (100 mm) diameter pipe located at the invert level of the detention basin. The preferred outlet is a perforated riser pipe (the typical outlet structure recommended in extended detention basins) which could improve the effluent water quality by allowing cleaner water from the top of the water quality volume to discharge sooner.

The hydraulic head requirement of a modified extended detention basin is small. Austin sand filters are not always suitable for installation in all locations as evidenced by the design of Pond 3 and Pond 2 in the study area. The lower head required for the modified extended detention basins matches the site characteristics in the study area.

The footprint of the modified extended detention basin is smaller than that of the equivalent Austin sand filter. Pond 3 occupies an area of 2110 m<sup>2</sup> including the basins, berms, and access areas. The area could be reduced to 1800 m<sup>2</sup> using the modified extended detention basin. The resulting footprint uses approximately 15% less area. Similarly, the area required at Pond 2 could be reduced from 9400 m<sup>2</sup> to 6600 m<sup>2</sup>, or a 30% reduction. The reduction in required area reduces the cost for the BMP as well.

The controller costs are more than offset by the reduced costs of materials and labor for constructing the sand filter portion of an Austin sand filter. The prototype controller/actuator constructed for the study cost \$1,550. The sand filter materials include the perforated underdrain pipes, clean-outs, filter sand, and the hazardous material valve between the sedimentation and filter basins. The total estimated cost of



Pond 3 is \$750,000 and could be reduced by a total of \$250,000. Using estimates from a 1993 EPA report sand filter costs are estimated to be in the \$2/ft<sup>3</sup> to \$9/ft<sup>3</sup> (\$71/m<sup>3</sup> to \$318/m<sup>3</sup>) based on water quality volume. Adjusting to 2005 dollars, the sand filter cost at Pond 3 ranges from \$87,000 to \$437,000 (USEPA, 1993).

The normally-closed valve operation of the modified extended detention allows the outlet structure to be operated as a hazardous material trap valve. In the event of a hazardous material spill, the controller can be deactivated to keep the valve closed until the hazardous material is removed. The valve can be closed to prevent discharge of the hazardous material if the valve is open (stormwater discharging).

The controller and the programmed algorithm performed well. The design is relatively simple and uses a readily available, inexpensive single sensor to control opening and closing the valve. The use of a controller, an electronic circuit, adds reliability concerns compared to the reliability of passive BMPs. The reliability issue was addressed by keeping the number of electronic and mechanical parts to a minimum and making field replacement of parts as easy as possible.

The outlet structure was modified based on minimizing retrofit costs. Standard perforated pipe and trash screen are recommended in future modified extended detention basins.

The effluent from the modified extended detention basin flowed over the clay liner of what was the originally installed sand filter of the BMP. The effluent of the sand filter discharged into a nearby creek and rising water in the creek backed into the filter basin. Connecting the extended detention basin to the filter basin effluent using a pipe is recommended to prevent backflow from the nearby creek, and to prevent additional materials from being introduced to the discharge.

Recommendations for enhancing the controller are based on experience operating the controller during the study period. The recommendations are based on improving ease of use, improving reliability, and improving fault detection. The suggested improvements are:

- Addition of a power on/off switch to disable the controller during maintenance.
- Addition of a reset switch to out the controller in a known state after maintenance or to reset the controller in mid-cycle.
- Addition of manual open/close switches. These switches should be located inside the controller enclosure. They would be used to manually open and close the valve for maintenance purposes. They could also be used in the event of a Hazardous material event.

- Addition of a low temperature cutoff to inhibit operation of the actuator if temperature is below a minimum temperature
- Addition external indicators to indicate a cycle is in progress. This indicator would allow an active cycle of the controller to be monitored without opening the enclosure.
- Addition of an external fault indicator. This indicator would allow the controller status to be monitored without opening the enclosure. This indicator would allow a fault status of the controller to be monitored without opening the enclosure
- Modification of the controller program to exercise the valve/actuator periodically (weekly) to prevent valve from seizing. The exercise of the valve should not take place if a controller cycle is active.

## References

- Adler, J. (1981). Automatic Device for Emptying a Detention Pond at a Constant Low Flow Rate and Velocity. Proceedings, International Symposium on Urban Hydrology, Hydraulics and Sediment Control. Lexington, KY: University of Kentucky.
- American Society for Testing and Materials (2000 & Reapproved 2002). *Standard Test Methods for Determining Sediment Concentration in Water Samples*. D3977-97.” vol. 11.02, Water (II), pp. 395-400.
- Barrett, Michael E. (2003). Performance, Cost, and Maintenance Requirements of Austin sand filters, *Journal of Water Resources Planning and Management*, ASCE, 129 (3), 234-242.
- Barrett, M., (1999). *Complying with the Edwards Aquifer Rules: Technical Guidance on Best Management Practices, Texas Natural Resource Conservation Commission Report RG-348*. <http://www.tnrcc.state.tx.us/admin/topdoc/rg/348/index.html>
- Caltrans, 2004, BMP Retrofit Pilot Program Final Report, California Department of Transportation, CTSW - RT - 01 – 050, Retrieved January 11, 2006 from <http://www.dot.ca.gov/hq/env/stormwater/>
- Capitol Area Metropolitan Planning Organization (2005). City of Austin Traffic Counts - 24 hour. Retrieved January 25, 2006, from Capitol Area Metropolitan Planning Organization (CAMPO) Web site: [http://www.campotexas.org/programs\\_rd\\_traffic\\_counts.php](http://www.campotexas.org/programs_rd_traffic_counts.php)
- Chapra, S. C. (1997). Chapter 17 – Sediments, *Surface Water Quality Modeling* (pp.295-306). Boston: WCB/McGraw Hill.
- City of Austin Environmental Criteria Manual* ( 2004). Retrieved November 2, 2005 from [http://www.amlegal.com/austin\\_nxt2/gateway.dll?f=templates&fn=default.htm&vid=amlegal:austin\\_environment](http://www.amlegal.com/austin_nxt2/gateway.dll?f=templates&fn=default.htm&vid=amlegal:austin_environment)
- City of Austin Watershed Ordinances* (2006a). Retrieved March 21, 2006, from City of Austin web site <http://www.ci.austin.tx.us/watershed/ordinances.htm>
- City of Austin Watershed Regulation Areas* (2006b). Retrieved March 21, 2006, from City of Austin web site <http://www.ci.austin.tx.us/help/edwardsaquifermap.htm>

- Driscoll, E. D., P. E. Shelley, and E. W. Strecker. (1990). "Pollutant loadings and impacts from highway stormwater runoff, Volume 1-IV." *Federal Highway Administration FHWARD-88-006*.
- Droste, R. L., (1997). Chapter 10 – Mass Balances and Hydraulic Flow Regimes. *Theory and Practice of Water and Wastewater Treatment*. (pp243-284). New Jersey: John Wiley and Sons, Inc.
- Gilbert, R. O., Chapter 13 – Characterizing Lognormal Populations in *Statistical Methods for Environmental Pollution Monitoring* (pp. 164-171), Van Nostrand Reinhold, New York.
- Gray, J. R., Glysson, G. D., Turcious, L. M., and Schwarz, G. E. (2000). "Comparability of Suspended-Sediment Concentration and Total Suspended Solids Data." *Water-Resources Investigations Report 00-4191*, U.S. Department of the Interior and U.S. Geological Survey.
- Greb, Steven R. and Bannerman, Roger T. (1997), "Influence of particle size on wet pond effectiveness." *Water Environment Research*, 69 (6): 1134-1138
- Grant, D. M., Dawson, B. D. (2001). *ISCO Open Channel Flow Measurement Handbook, Fifth Edition*. ISCO, Inc., Lincoln, Nebraska.
- Haested Methods, Durrans, S. R. (2003). Chapter 15 – Regulatory and Environmental Issues. *Stormwater Conveyance Modeling and Design* (pp. 575-603). Waterbury, CT: Haested Press.
- Hamilton, R. S., & Harrison, R. M. (1991). Chapter 5 - Highway Runoff Quality, Environmental Impacts and Control (T. Hvitved-Jacobson & Y. A. Yousef, Eds.). In *Highway Pollution* (pp. 165-208). New York: Elsevier.
- IDEC Smart Relay User's Manual*, (2001). IDEC Izumi Corporation, Manual No FL9Y-B827.
- Karamalegos, A. M., Barrett, M. E., Lawler, D. F. and Malina, J. F. (2005). *Particle Size Distribution of Highway Runoff and Modification Through Stormwater Treatment*. CRWR Online Report 05-10, <http://www.cwrw.utexas.edu/online.shtml>
- WERF (2005). Lampe, L., Barrett, M., Woods-Ballard, B., Kellagher, R., Martin, P., Jeffries, C. and Hollon, M. (2005). Final Report 2005, Performance and Whole Life Costs of Best Management Practices and Sustainable Urban Drainage Systems. Water Environment Research Foundation, Final Report for Phases 1 and 2 of Project 01-CTS-21T
- Landau, C. R., 2001. Optimum orientation of solar panels, <http://www.macslab.com/optosolar.html>.

- Li, Y., Kayhanian, M., & Stenstrom, M. K. 2005. Particle Size Distribution in Highway Runoff. *Journal of Environmental Engineering* – ASCE, 131 (9): 1267-1276.
- Lower Colorado River Authority (2006). *Highland Lakes Watershed Ordinance Water Quality Technical Management Technical Manual*. Fourth Edition, Effective February 1, 2006.
- Lower Colorado River Authority 2005. *Lower Colorado River Authority Highland Lakes Watershed Ordinance*. Approved: November 16, 2005. Effective: February 1, 2006. Retrieved March 27, 2005, from <http://www.lcra.org/water/npsp.html>.
- Martin, E. H., (1989). Mixing and Residence Times of Stormwater Runoff in a Detention System, *Proceedings of an Engineering Foundation Conference on Current Practice and Design Criteria for Urban Quality Control - ASCE*, 164-179.
- National Climate Data Center, Daily Normal Data, 2006 retrieved on February 24, 2006, <http://www.ncdc.noaa.gov/oa/ncdc.html>
- Papa, F., Adams, B.J., Guo, Y. (1999). Detention Time Selection for Stormwater Quality Control Ponds. *Canadian Journal of Civil Engineering*, 26, 72-82.
- Randall, C. W., Grizzard, T. J. (1983). Chapter 7 - Detention and Flow Retardation Devices. *Stormwater Management in Urbanizing Areas*, New Jersey: Prentice Hall.
- Randall, C. W., Ellis, K., Grizzard, T. J., Knocke, W. R. (1982). Proceedings of the Conference on Stormwater Detention Facilities (DeGroot, W. Editor), *Urban runoff Pollutant Removal by Sedimentation* (pp 205-219 ). New York: ASCE
- Sansalone, J. & Cristina, C. M. (2004). First Flush Concepts for Suspended Solids in Small Impervious Watersheds. *Journal of Environmental Engineering*, ASCE 130 (11): 1301-1314.
- Shammaa, Y., Zhu, D. Z., Gyurek, L. L. Labatiuand k, CW (2002). Effectiveness of Dry Ponds for Stormwater Total Suspended Solids Removal, *Canadian Journal of Civil Engineering*, 29 (2): 316-324.
- Stenstrom, M. K. & Kayhanian, M. (2005). *First Flush Phenomenon Characterization*, CTSW-RT-05-73-02.6.
- Strecker, E.W., Quigley, M.M., Urbonas, B.R., Jones, J.E., and Clary, J.K., (2001). Determining Urban Storm Water BMP Effectiveness, *Journal Water Resources Planning and Management*, Vol. 127, No. 3, pp. 144-149.

- Texas Commission on Environmental Quality (2006a). *Edwards Aquifer Map*. Retrieved March 21, 2006, from TCEQ web site  
<http://gis2.tceq.state.tx.us/website/iredwards1/viewer.htm>
- Texas Commission on Environmental Quality (2006b). *Edwards Aquifer Technical Guidance Manual*. June 20, 2005, Retrieved January 2, 2006 from  
[http://www.tceq.state.tx.us/comm\\_exec/forms\\_pubs/pubs/rg/rg-348/rg-348\\_712011.pdf](http://www.tceq.state.tx.us/comm_exec/forms_pubs/pubs/rg/rg-348/rg-348_712011.pdf)
- Title 30 Texas Administrative Code Chapter 213, Retrieved January 6, 2006 from  
[http://info.sos.state.tx.us/pls/pub/readtac\\$ext.ViewTAC?tac\\_view=4&ti=30&pt=1&ch=213](http://info.sos.state.tx.us/pls/pub/readtac$ext.ViewTAC?tac_view=4&ti=30&pt=1&ch=213)
- U.S. Environmental Protection Agency (USEPA). 1993. *Guidance Specifying Management Measures for Sources of Nonpoint Pollution in Coastal Waters*. EPA-840-B-92-002. U.S. Environmental Protection Agency, Office of Water, Washington, DC.
- U.S. Environmental Protection Agency (2004). *Safe Drinking Water Act 30th Anniversary*. EPA 816-F-04-030. U.S. Environmental Protection Agency, Office of Water, Washington, DC. Retrieved March 27, 2005, from  
<http://www.epa.gov/safewater/sdwa/30th/factsheets/understand.html#3>
- U.S. Environmental Protection Agency (2001). *Water Quality Standards, Policy Guidance, Fact Sheet*. EPA-823-F-01-003. U.S. Environmental Protection Agency, Office of Water, Washington, DC. Retrieved March 27, 2005, from  
<http://www.epa.gov/ost/standards/factmoa.html>.
- U.S. Environmental Protection Agency (2003). *Index to EPA Test Methods*. United States Environmental Protection Agency. Retrieved March 17, 2005, from  
<http://www.epa.gov/region01/oarm/testmeth.pdf>.
- U.S. Environmental Protection Agency (2005). *National Management Measures to Control Nonpoint Source Pollution from Urban Areas*. EPA-841-B-05-004. U.S. Environmental Protection Agency, Office of Water, Washington, DC.
- Watershed Management Institute (1997) *Institutional Aspects of Urban Runoff Management: A Guide for Program Development and Implementation*, Watershed Management Institute. Ingleside, MD.

## **Appendix A**

Flowlink<sup>®</sup> graphs and graphs created from exported Flowlink<sup>®</sup> data for each storm analyzed in the summary tables in the main text are shown in Appendix A. The graphs can be used to understand the overall dynamics of each storm. Of interest are timing of rainfall relative to the basin level and the timing of the release from the basin.

# July 27, 2005 Storm

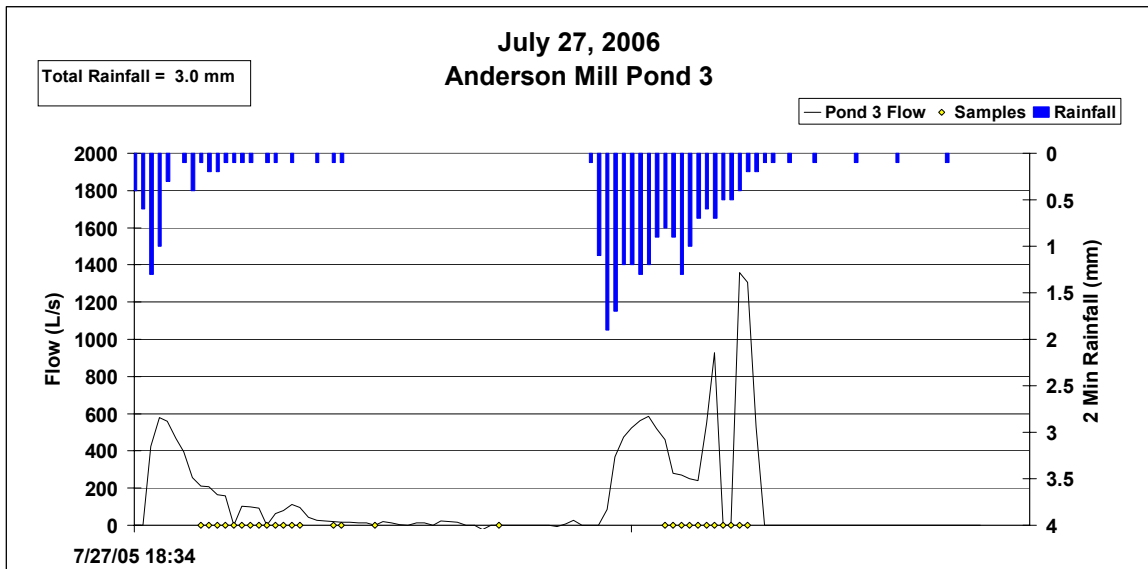
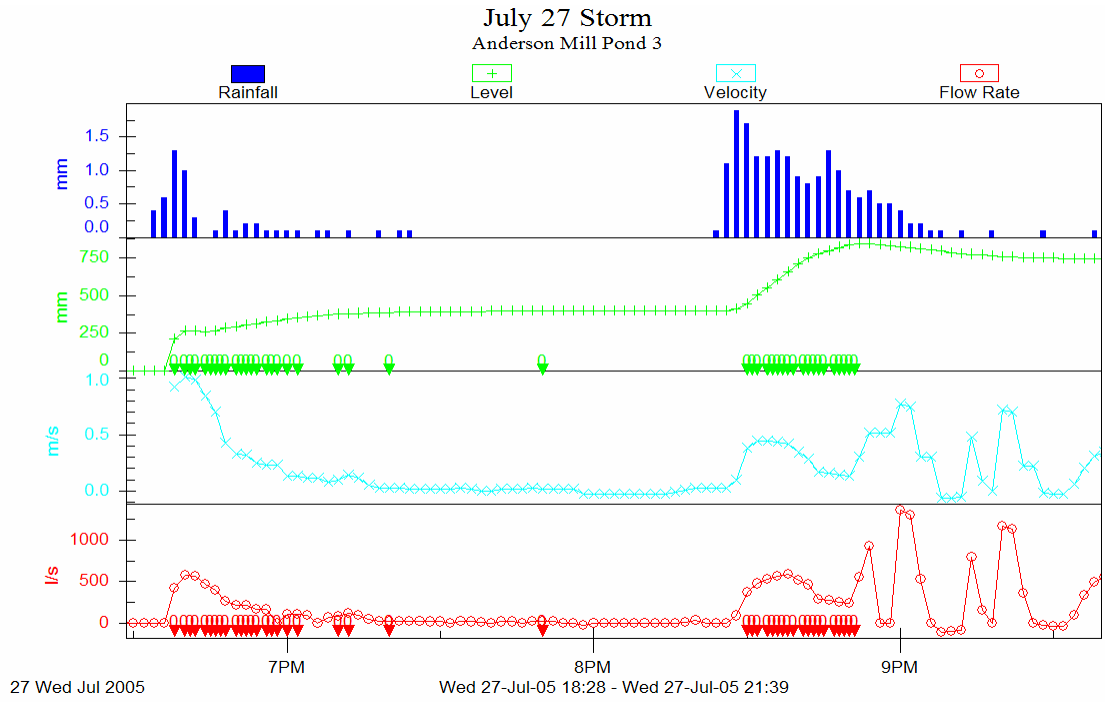



## August 4-5, 2005 Storm Graphs

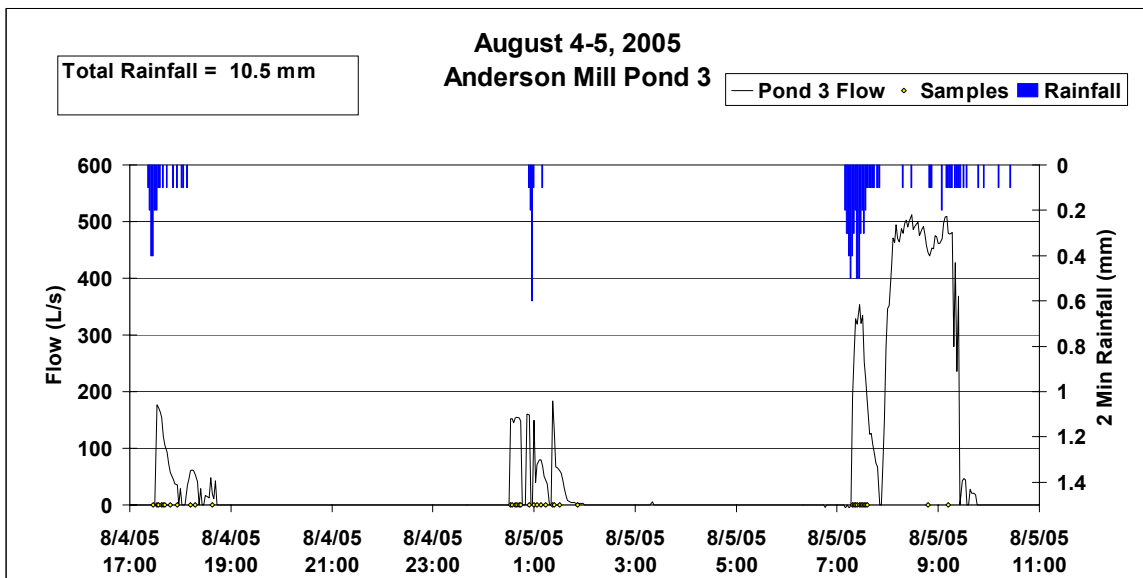
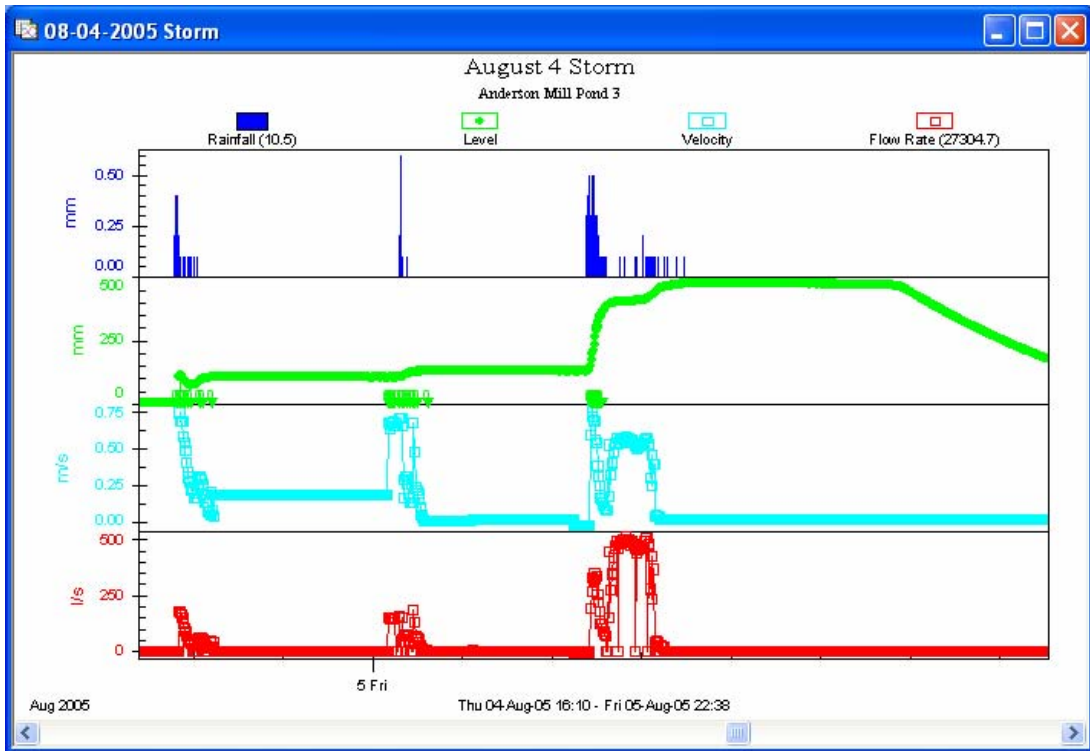

# August 16, 2005 Storm Graphs

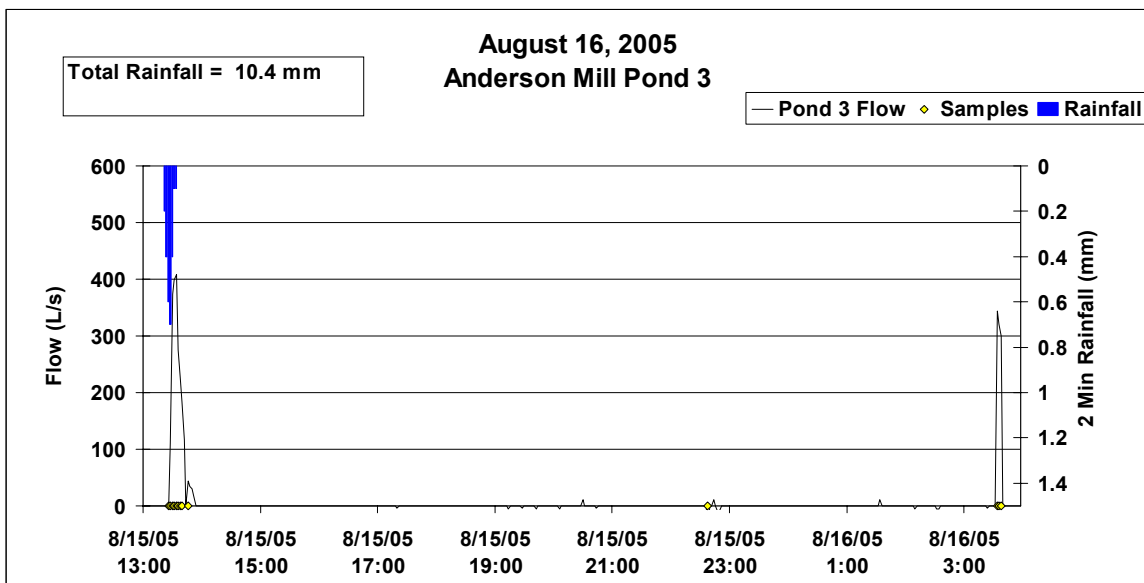
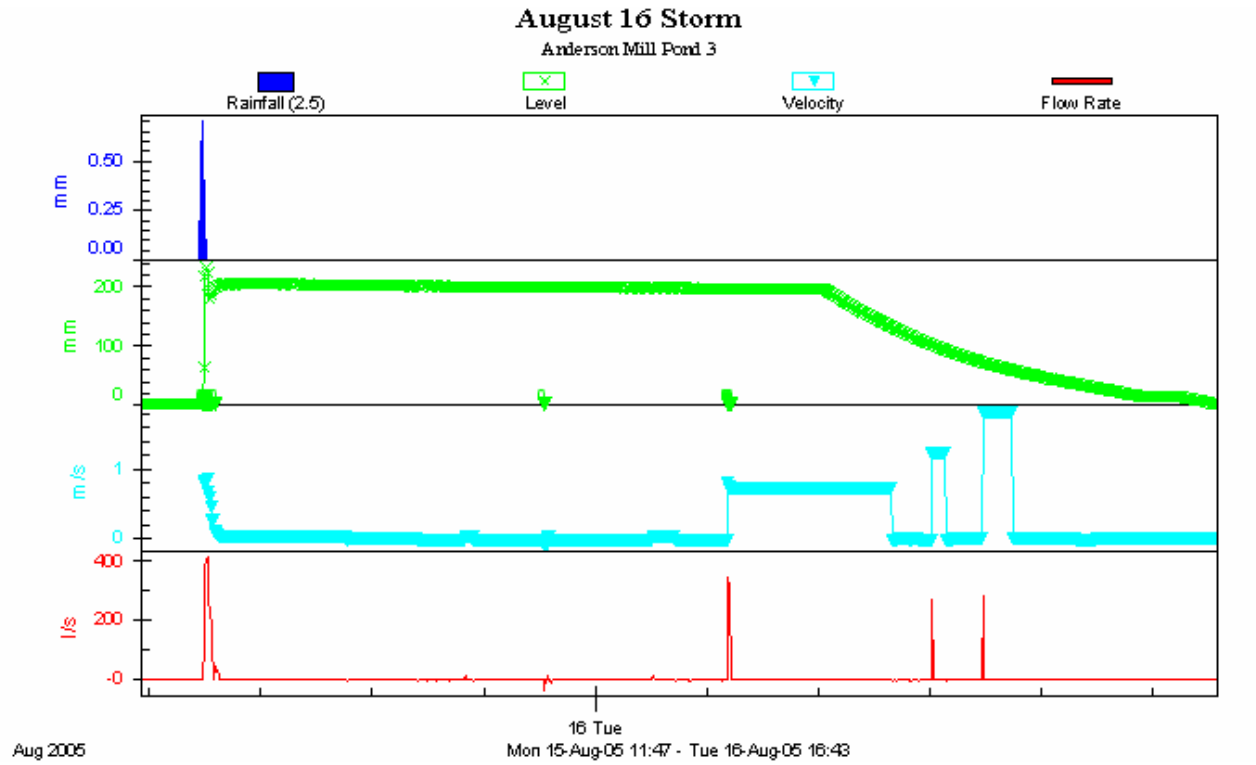

# October 10, 2005 Storm Graphs

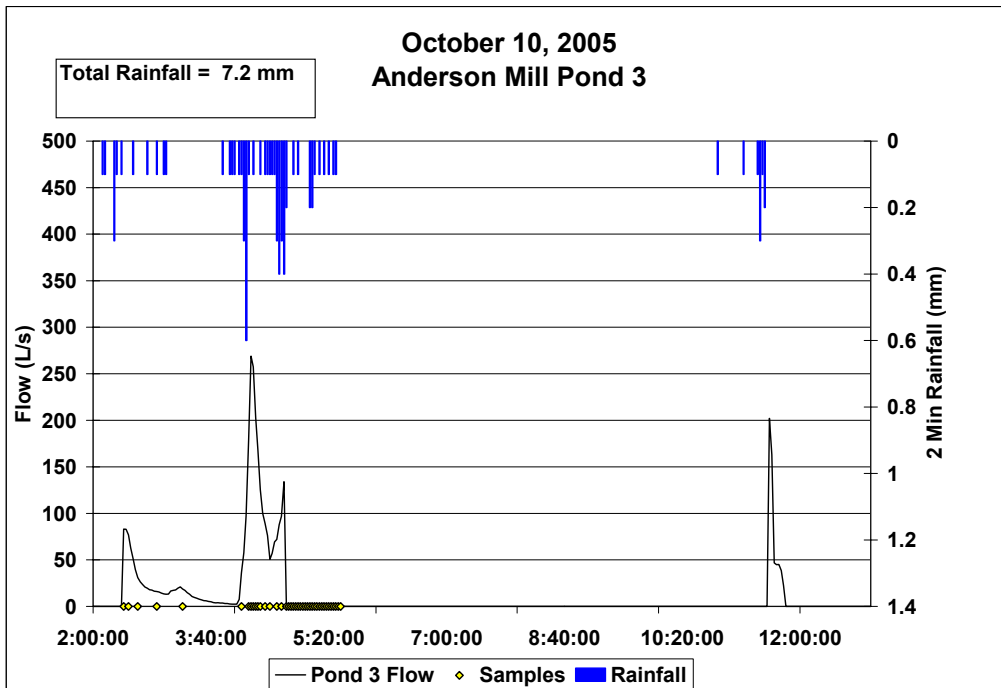
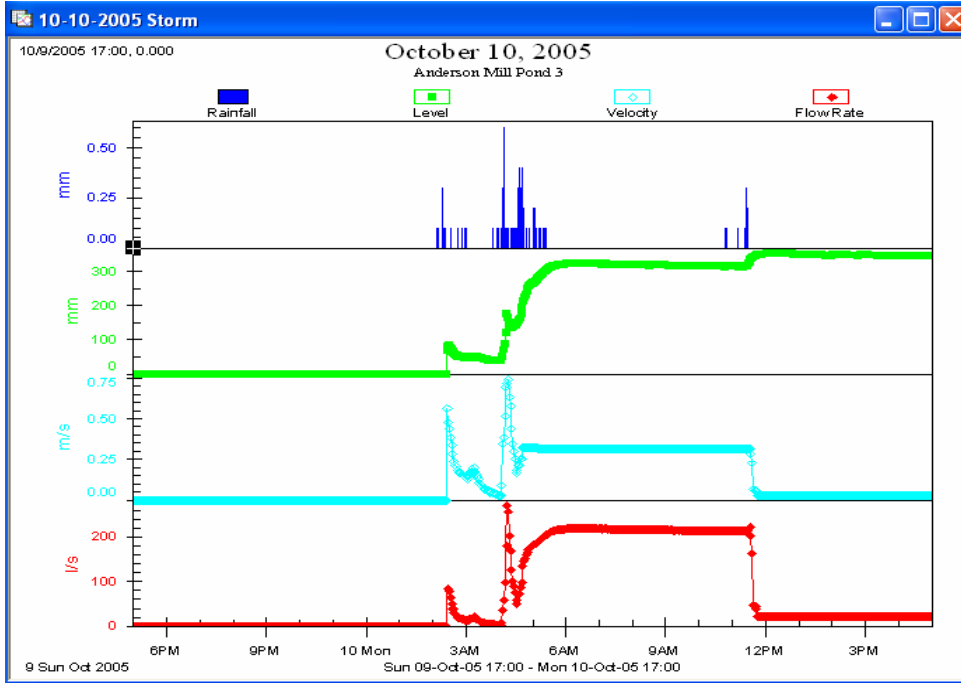

# October 31, 2005 Storm Graphs

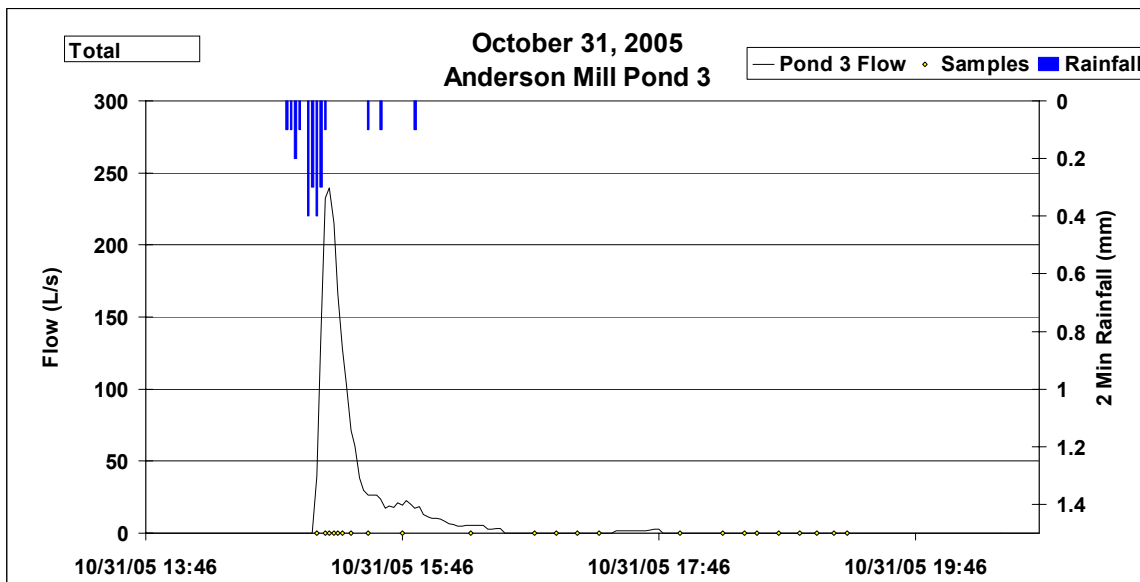
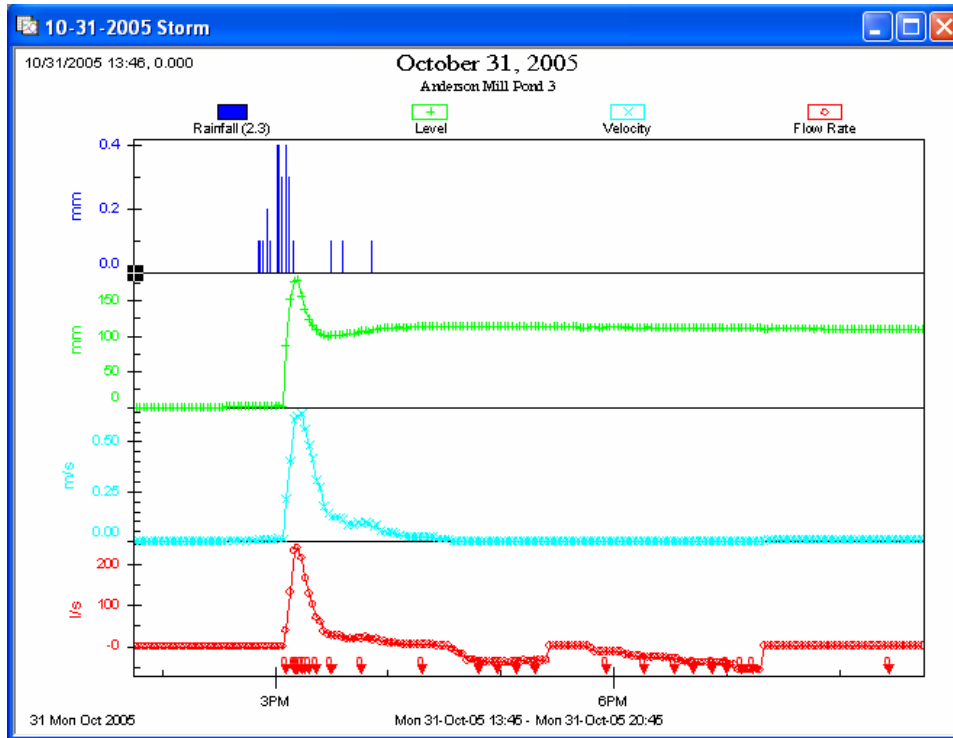

# November 26, 2005 Storm Graphs

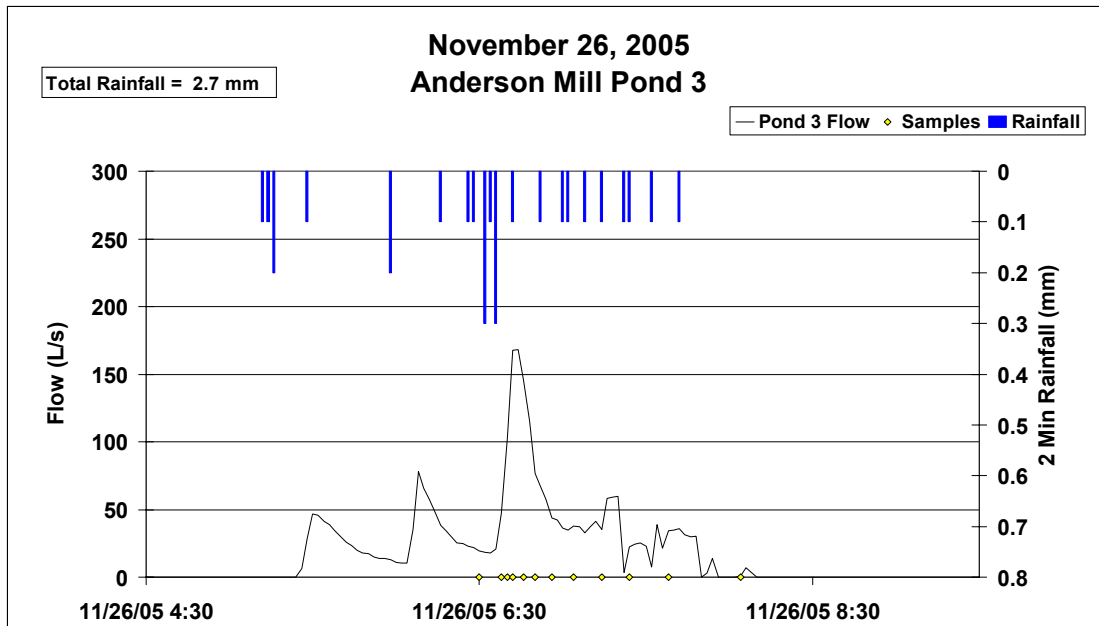
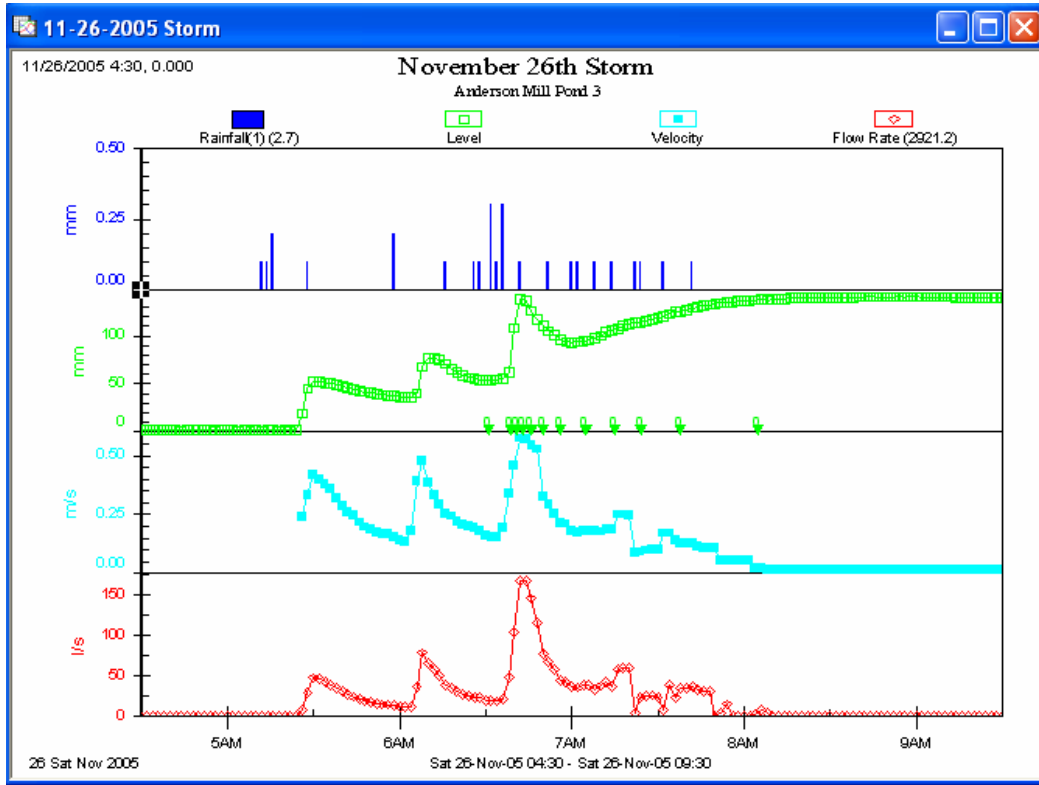

# January 28, 2006 Storm Graphs

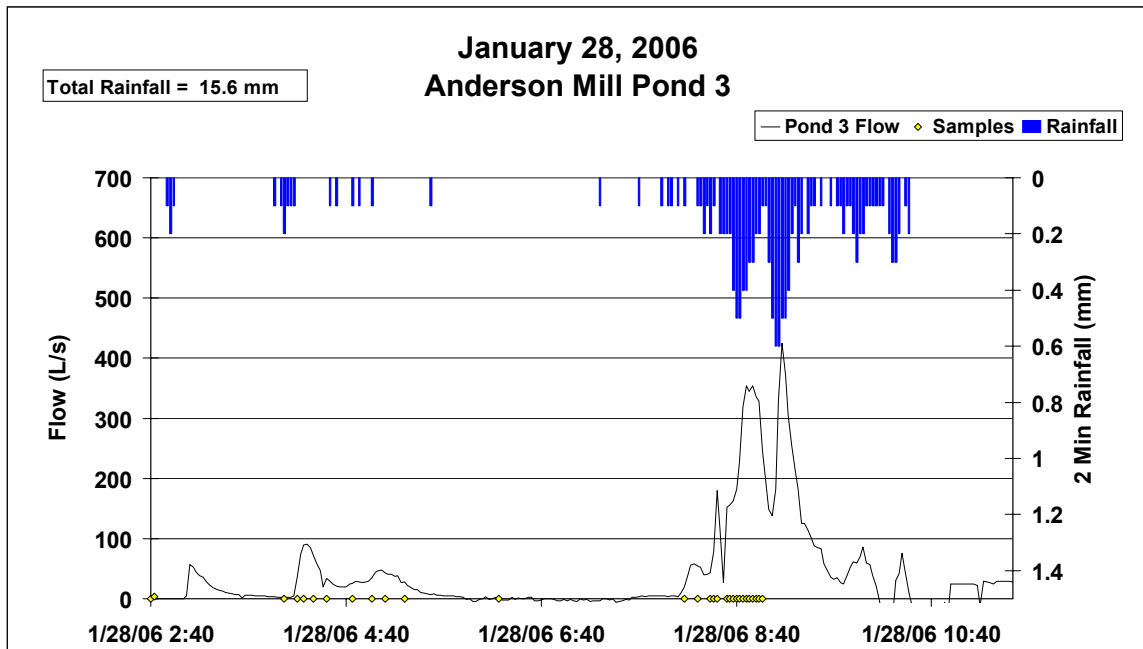
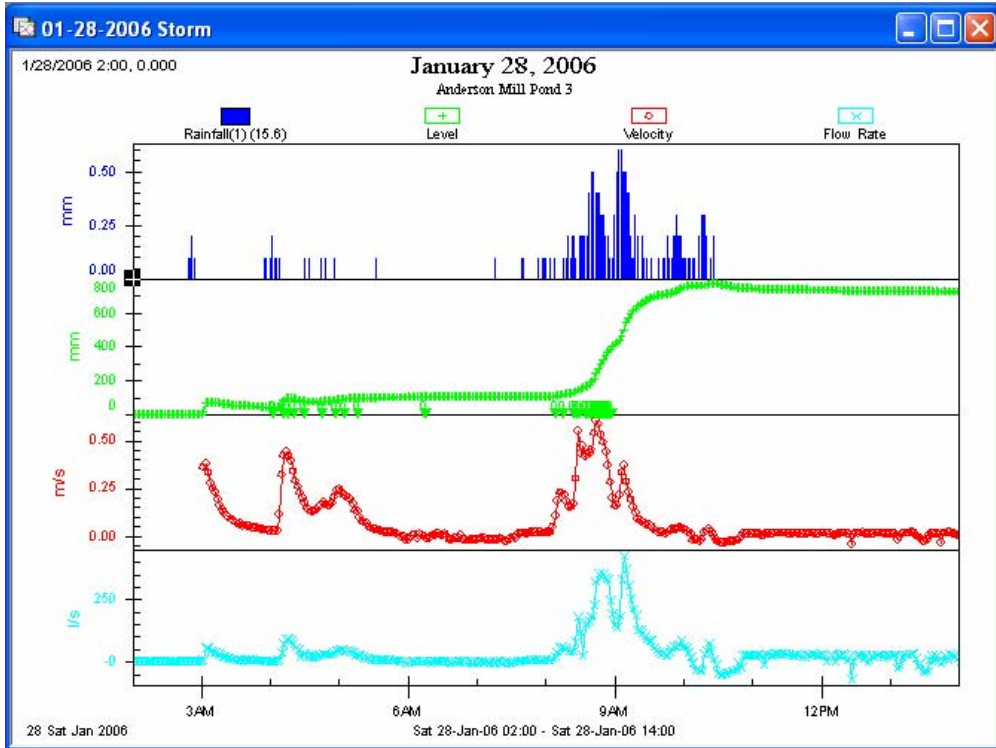

## February 25, 2006 Storm Graphs

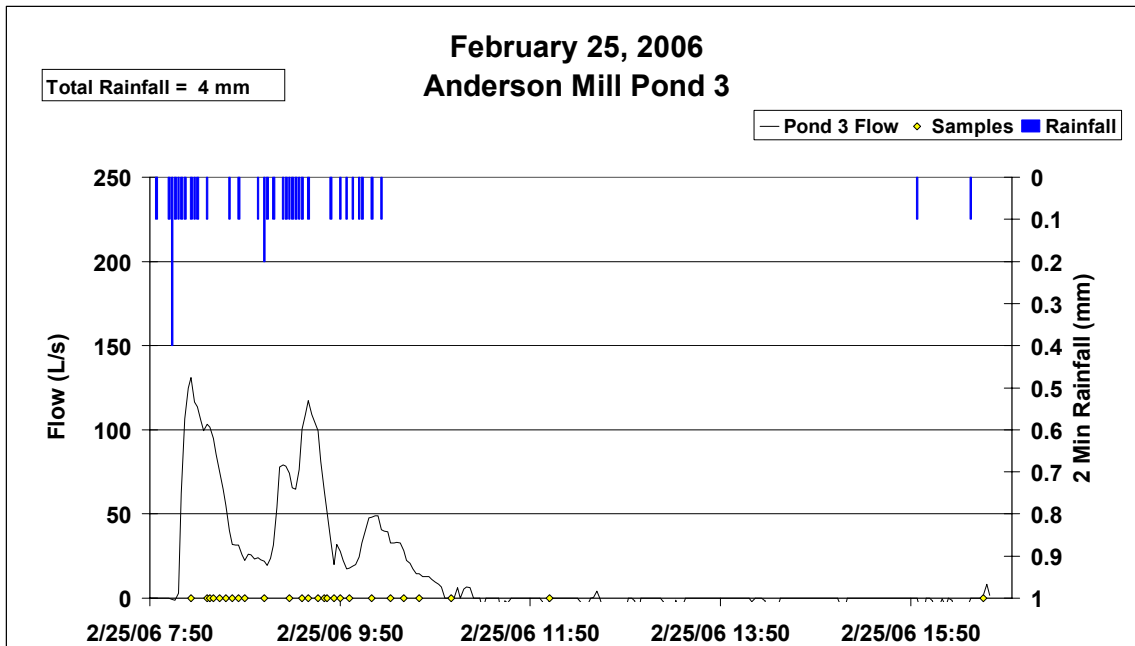
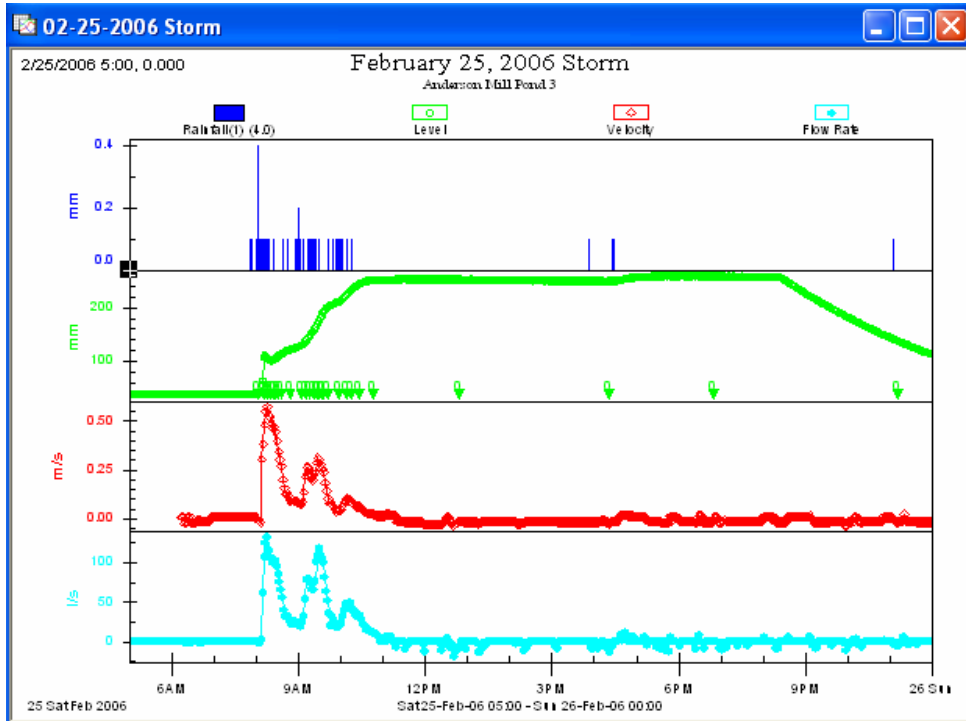

## March 8, 2006 Storm Graphs

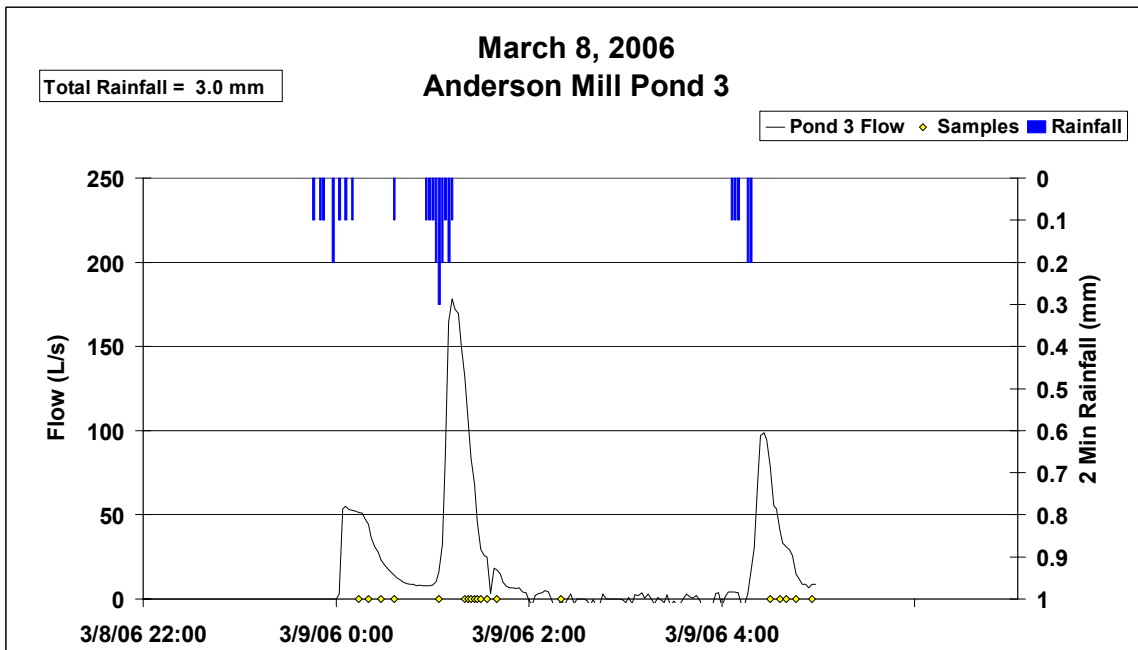
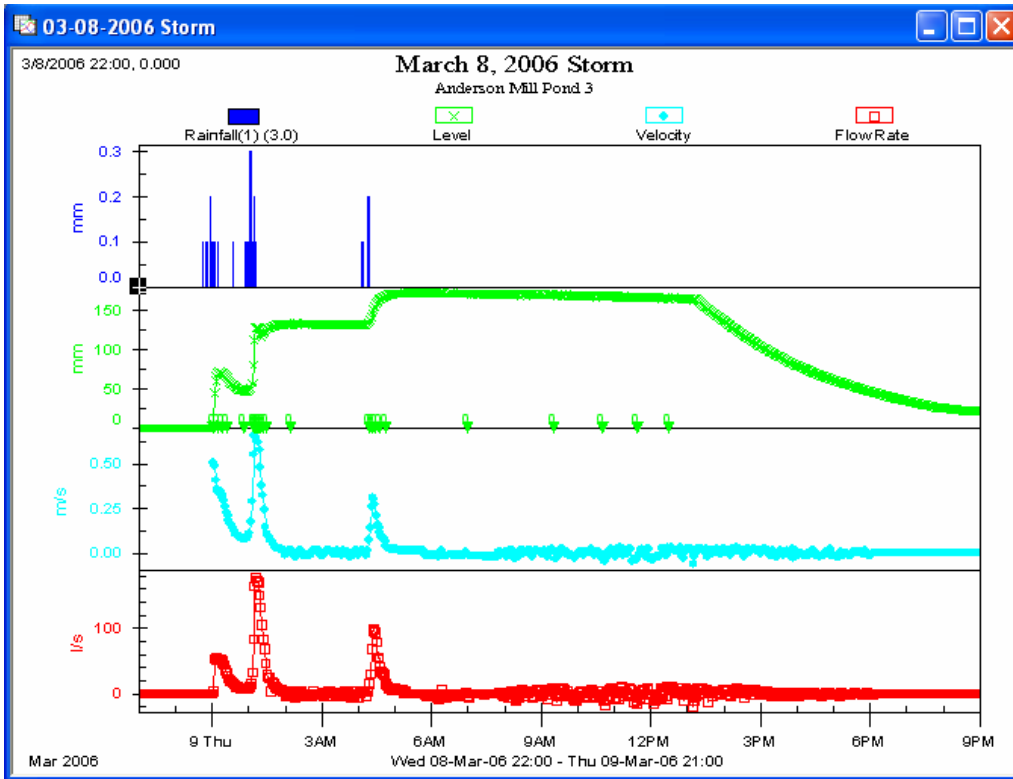



# March 28, 2006 Storm Graphs

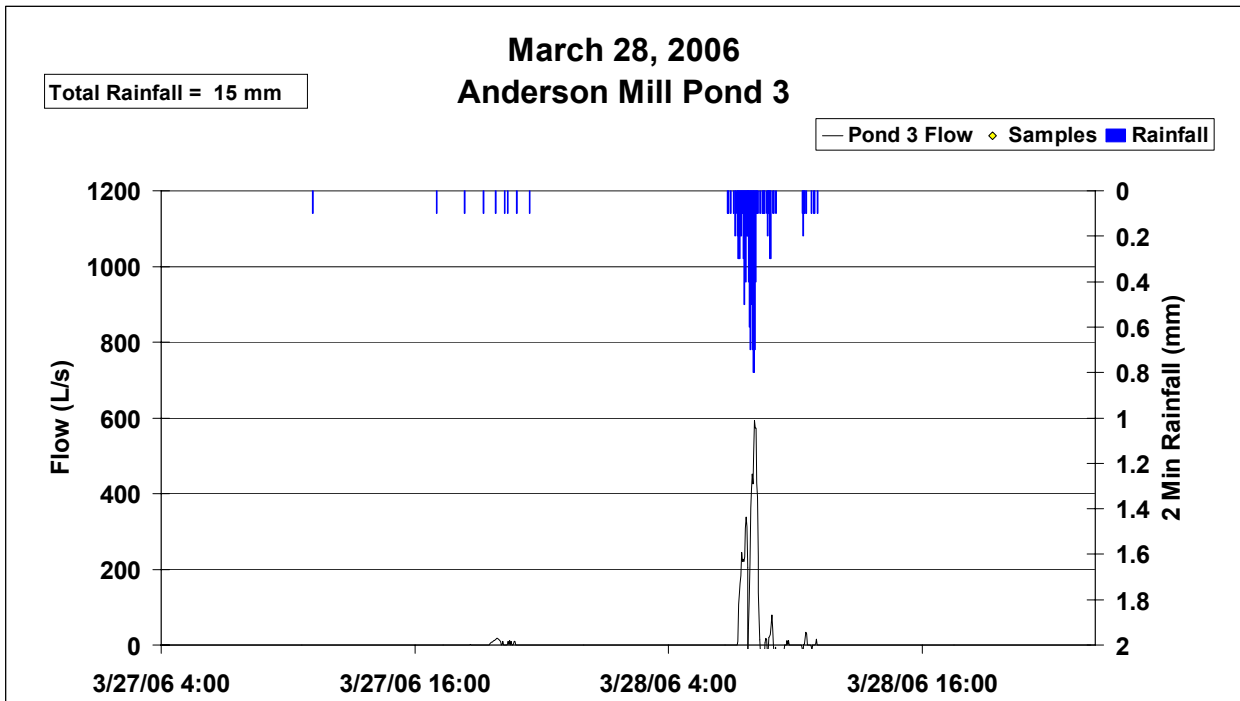
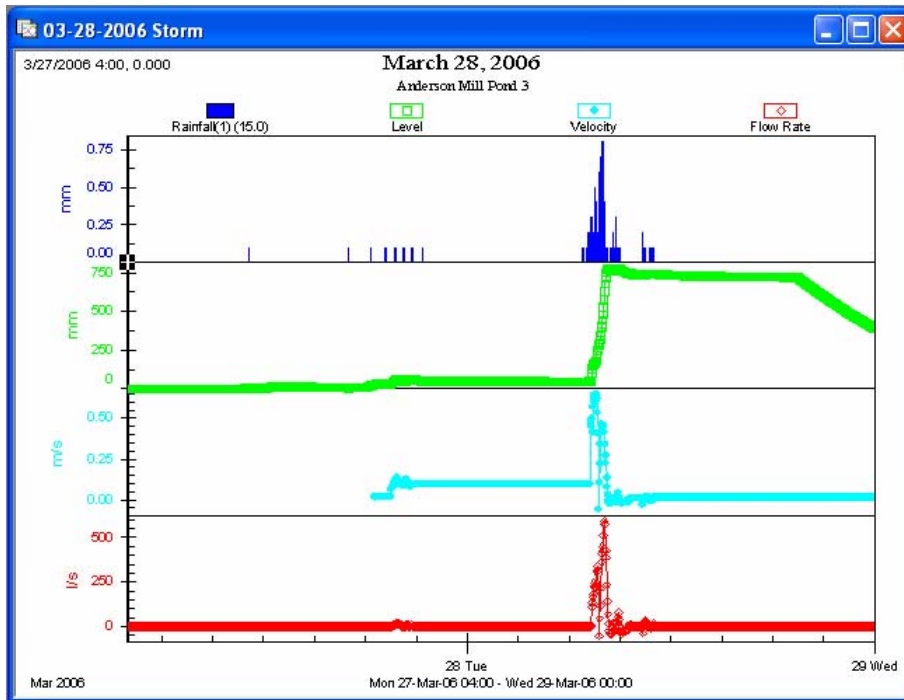

# April 20, 2006 Storm Graphs

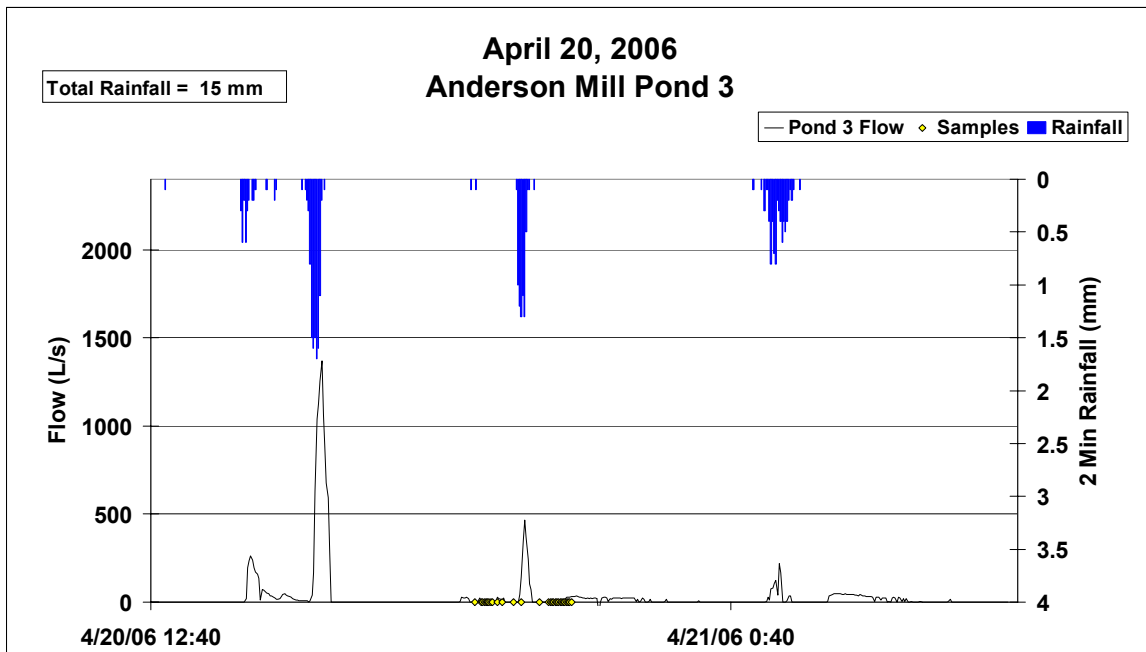
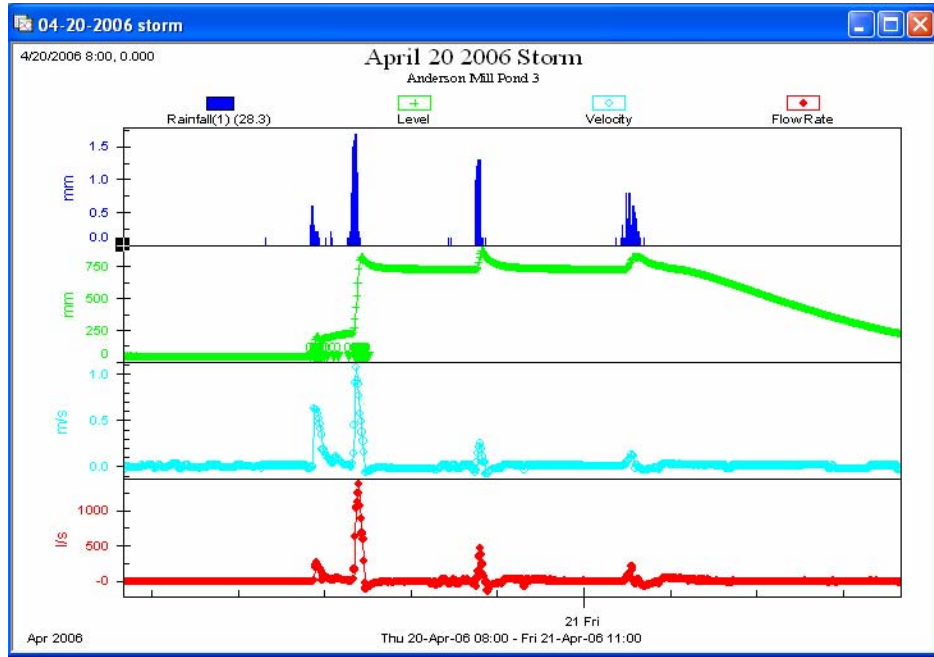

## April 29, 2006 Storm Graphs

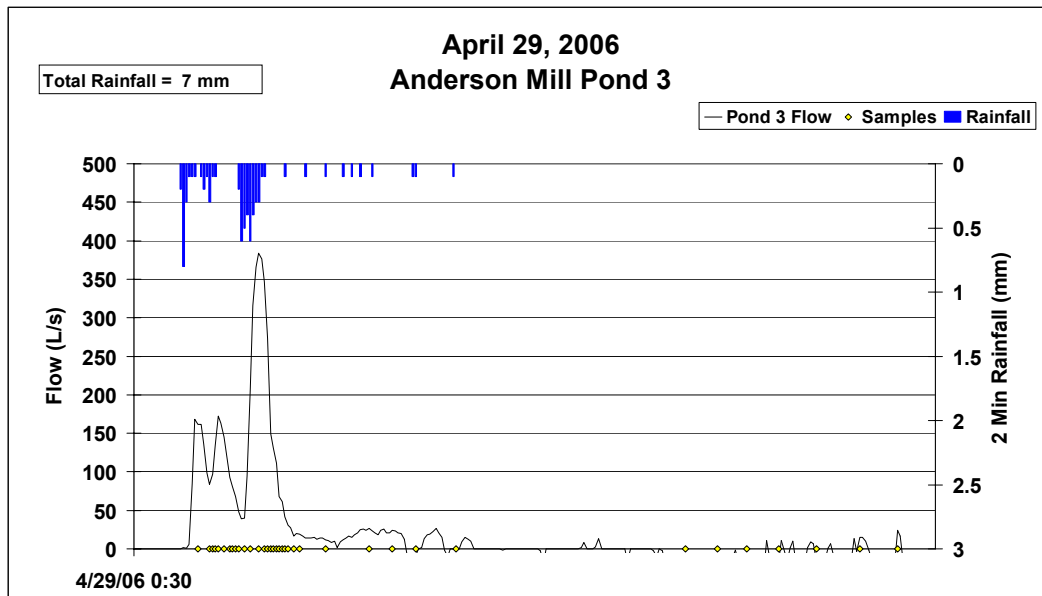
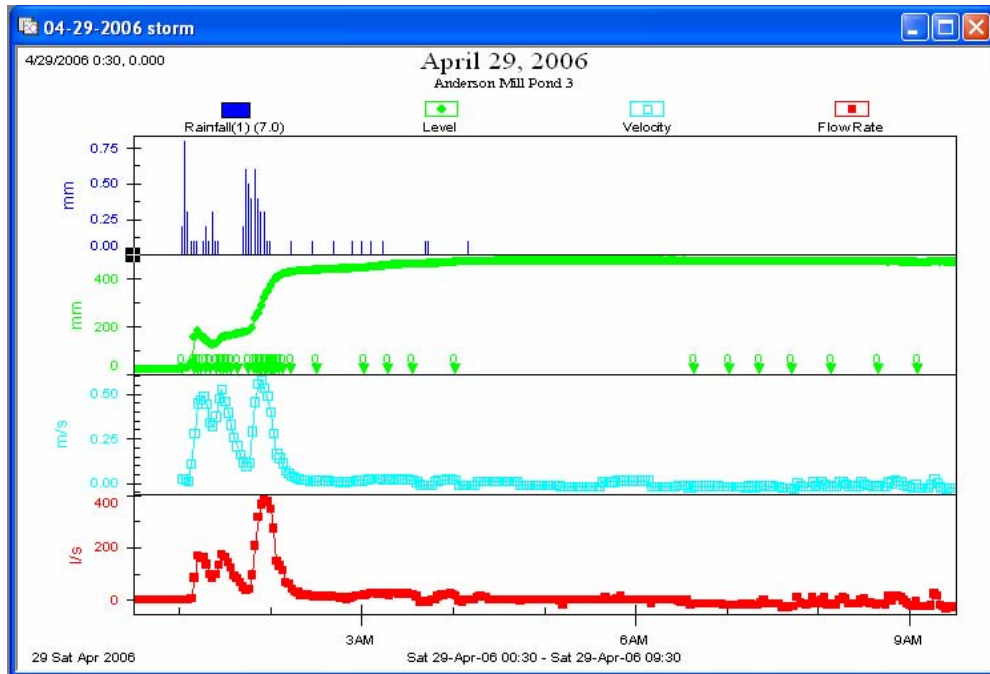

# May 6, 2006 Storm Graphs

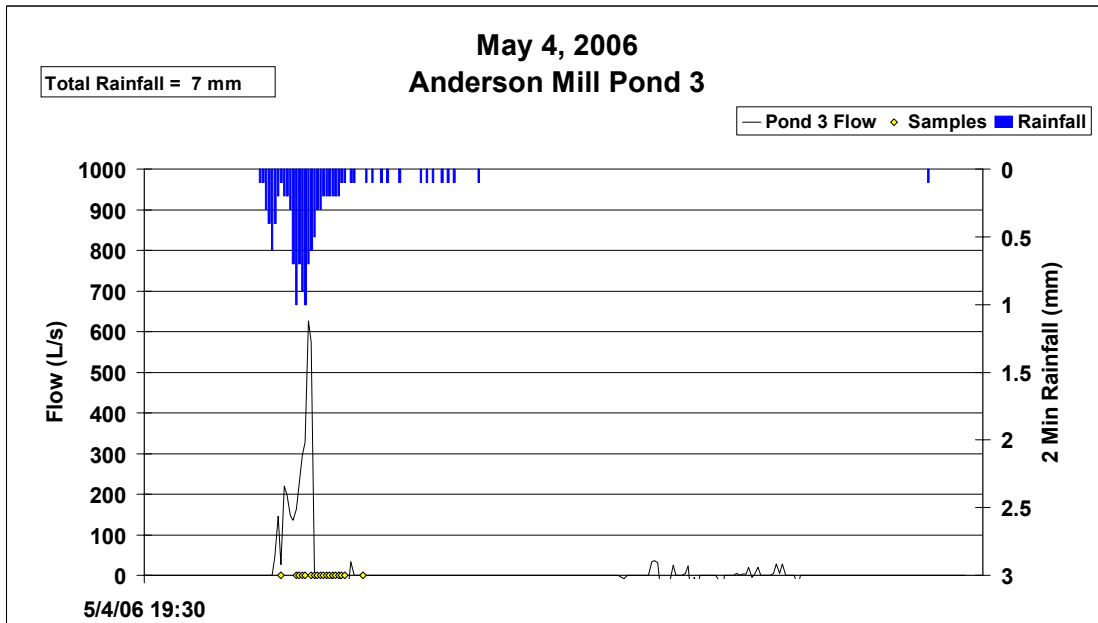
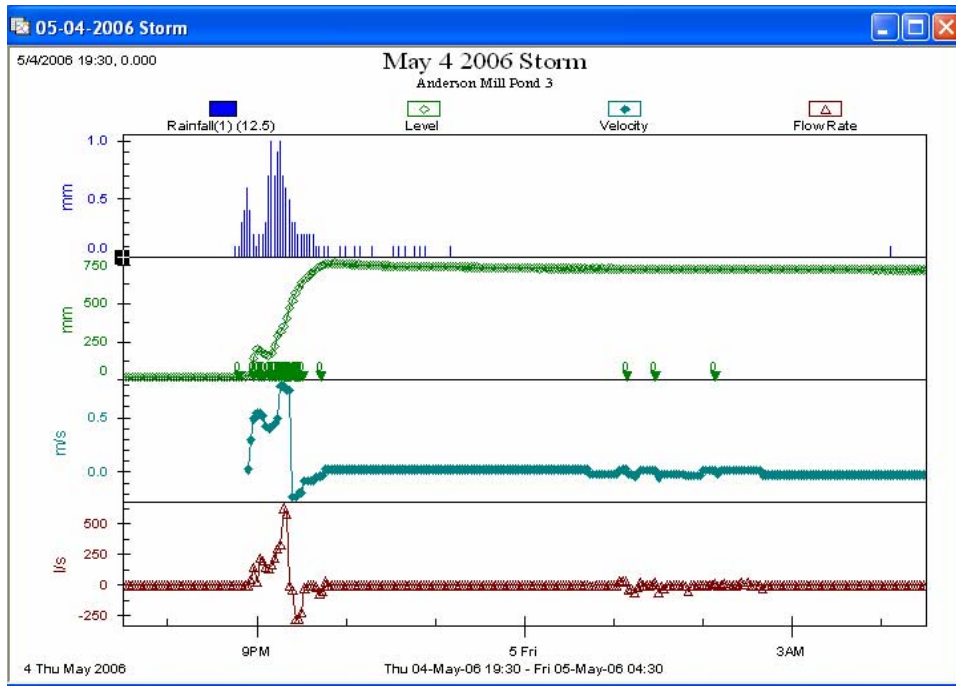

## Appendix B – Controller Bill of Materials

Item	Manufacturer	Description	Stock Number	Unit Price	Quantity	Extension
1	Ancor Scientific	Eco-Float float switch, Normally Open Pipe Mount, 20 feet cable	Eco Float	35.00	1	35.00
2	BP	Solar Panel, 10W, universal frame	BP SX 10U	126.00	1	126.00
3		12V Battery, 36.1Ah	8GU1	59.00	1	59.00
4	Morningstar	Morningstar solar controller, 12V, 20Amp	Sunsaver20-12V	79.00	1	79.00
5	Southwest Photovoltaic	Aluminum enclosure, 15.625 x 10.125 x	BBA-2	139.00	1	139.00
6	Southwest Photovoltaic	Side of pole mount for SX-10 solar panel	HPM 5-10 Lo-Pro	15.00	1	15.00
7	Southwest Photovoltaic	10' solar panel cable	NA	12.00	1	12.00
8	Southwest Photovoltaic	battery cable	NA	5.00	1	5.00
9	IDEC Corporation	SmartRelay, With Display 8 PNP in/4 Relay out, W/2 Analog, 12/24	FL1C-H12RCE	135.92	1	135.92
10	Keystone (Tyco)	Butterfly Valve, 6" CI ALBZ EPDM Lugged 250 PSI Bare Stem F222	784-703-060-222-302	116.32	1	116.32
11	Avid (Tyco)	12V Actuator, EPI-6 12V On-Off service	K2CG2K2BCDECYYYYY	680.56	1	680.56
12	Tyco	Adapter 3/4" x 1/2" A/F	102-254-060-099-004	6.00	1	6.00
13	MSD Inc	Relay, 12VDC, 15A contact rating, DPDT	MSD-782XBX4L-12D	5.90	2	11.80
14	MSD Inc	35mm Aluminum DIN rail		4.00	1	4.00
15	MSD Inc	2P DIN/Panel socket (for realys		4.80	2	9.60
16	Local	Terminal Block		2.79	1	2.79
17	Local	Red Wire		12.99	1	12.99
18	Local	Black Wire		12.99	1	12.99
19	Local	Green Wire		12.99	1	12.99
20	Local	White Wire		12.99	1	12.99
21	Local	Blue Wire		12.99	1	12.99
22	Local	Conduit		17.99	1	17.99
23	Local	U-Bolts		1.79	3	5.37
24	Local	2" Mounting Pole		12.99	1	12.99
25	Local	Concrete		4.39	1	4.39
26	Local	Conduit fittings		1.19	1	1.19
27	Local	Concrete fasteners		6.49	1	6.49
28	Local	Conduit tie-downs		4.29	1	4.29
					<b>Total</b>	<b>1554.65</b>

## **Appendix C – Controller Operation and Maintenance**

### **Starting the Controller**

The controller can be started by connecting the Load wires from the Morningstar Sunsaver20 Solar Controller to the terminal block connectors as shown in the schematic (Red wire from Sunsaver20 pin 6, black wire from pin 5). Once power is applied the PLC initializes and runs the preloaded program. The program attempts to close the butterfly valve by issuing a 10 s pulse to the actuator. Relay noise can be heard at the beginning and end of the 10 s pulse.

Note that this procedure will remove power from the PLC and relays. It does not interrupt the solar panel/battery circuit.

### **Stopping the Controller**

The controller can be turned off by disconnecting power from Morningstar Sunsaver20 Solar Controller to the terminal block connectors as shown in the schematic (Red wire from Sunsaver20 pin 6, black wire from pin 5).

### **Manual Valve Operation**

The valve can be manually operated using the crank wheel located on the side of the actuator. Manual operation can be used during BMP maintenance activities, or in the control hazardous material that has entered the BMP.

### **Field Replaceable Units**

The Controller is a modular assembly making replacement of most parts relatively simple. The following parts are considered field replaceable units:

- Relays – socketed, can be easily replaced without tools
- Battery – disconnect battery leads from battery terminals to replace
- Programmable Logic Controller – disconnect wires from inputs and outputs, snap loose from rail.
- Solar Panels – disconnect wires from terminal block and pull cable out of enclosure
- Float switch – disconnect wires from terminal block and release cable strain relief inside enclosure. Wire to the float switch must be pulled through conduit to remove float switch.
- Solar Controller – disconnect leads from solar panel, load, and battery.

### **Maintenance Activities**

A visual inspection of controller functionality should be made after each storm. A visual inspection should take place after a period of time sufficient for the controller to have drained the BMP and for the valve to have closed in preparation for the next storm event.

- A visual inspection should consist of the following steps:
- Verify that the BMP has been completely drained
- Verify that the float switch is not obstructed
- Verify that the valve is in the closed position
- Note any obvious damage to the controller, valve, actuator, or float switch.
- Optionally, the controller enclosure can be opened, and the cycle counter can be inspected to determine the number of storm cycles the controller has detected.

A complete inspection of the controller and valve/actuator should take place annually. An annual inspection of the controller should consist of:

#### Inspection

- Open the enclosure and inspect the interior. Clean out any insects or debris from insects.
- Inspect the battery for signs of leakage or corrosion on the terminals.
- Inspect the solar panels for damage. Clean the surface if necessary. Make sure the panel is oriented properly (South facing, 26 degree tilt).
- Inspect the electronics for signs of corrosion, wear, or other damage
- Inspect the float switch. Look for signs of damage or wear. Make sure there are no obstructions near the float switch.
- Inspect the actuator for signs of damage.

- Inspect the valve for signs of damage

### Verify Operation

- Manually trigger the controller by lifting the float switch until the internal roller rolls to the back of the float.
- Using the front panel and LCD, verify that the controller has been triggered (See LCD Front Panel Operation).
- Manually open the valve
- Disconnect power to the PLC by disconnecting the lead from the SunSaver20 pin 6 to the terminal block pin 1 (red wire). Wait 5 seconds and reconnect. The controller should initialize and close the valve.

### **LCD Front Panel Operation**

The LCD front panel and the keypad on the IDEC FL1C PLC can be used to monitor status of the Automatic controller, and to adjust timing parameters. The following guide illustrates the use of the front panel and keypad to perform these functions.

Turn on the power to the unit using the power switch. An “hour glass” will appear on the LCD for several seconds indicating the PLC is starting up. The program automatically starts, and the following menu appears:

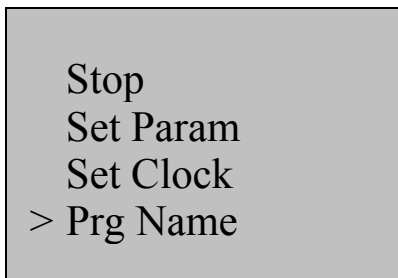

In this state, the controller program is active, or in the “run” state. The controller will attempt to close the valve, and will then wait for a trigger from the level sensor to initiate the detention/drawdown sequence.



Pressing the “esc” button will put the PLC in the Time/Date display mode as shown below. The controller program is still in the “run” state.

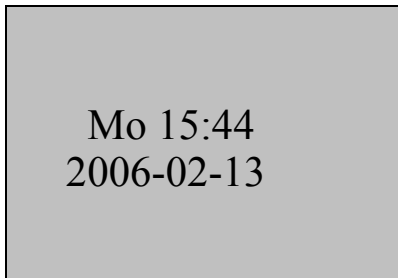

Mo 15:44  
2006-02-13

Pressing the “esc” again will return the display to the menu show below. In order to check the program revision, use cursor keys to select “Prg Name”

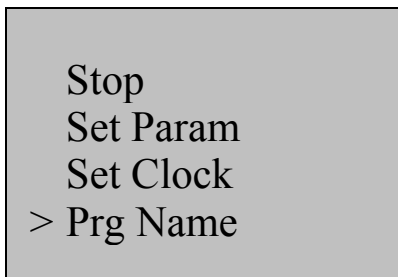

Stop  
Set Param  
Set Clock  
> Prg Name

Press “OK” to display the program name and revision

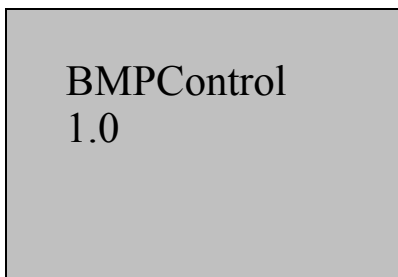

BMPControl  
1.0

Press “esc” to get back to main menu. Now use the cursor keys to select “Set Param.” This will allow parameters used in the controller’s program to be adjusted.

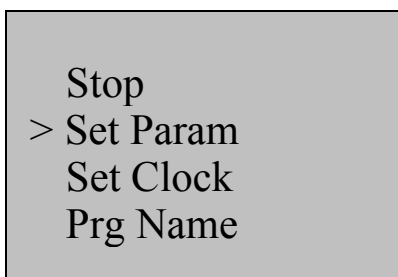

Stop  
> Set Param  
Set Clock  
Prg Name

Press “OK” and the first adjustable parameter will be selected. The Retention Time (RetTime) is the first parameter to be displayed.

```
RetTime
TH =00:10s
TL =12
Ta =00:00
```

The cursor keys can be used to select a one of the three timing parameters as show above. TH is the pulse for the actuator, and is set for the minimum time needed to turn the actuator one quarter turn.

- TL is the retention time value. It can be adjusted as required.
- Ta is the active time of the timer. It can be used as a means to check the status of the controller once a trigger occurs.

```
CycleCnt
On = 1
Off = 1
Cnt = 0
```

The Cycle Counter (CycleCnt) Cnt value indicates the number of times the controller has been triggered. It can be used to determine the number of storms that have triggered the controller since the controller was powered up.

```
PwrUpRes
T =10:00s

Ta =10:00s
```

The Power up reset (PwrUpRes) timer generates a reset pulse at power up. It should not be adjusted.

Reset  
TH =01:00s  
TL =00:00s  
Ta =00:00

The Reset (Reset) timer generates a reset pulse at the end of a cycle to reset the internal circuitry. It should not be adjusted.

Drwdwn  
TH =10:00s  
TL =2:00h  
Ta =00:00

The drawdown timer (Drwdwn) generates a pulse to the actuator at the end of the drawdown period. The pulse width is indicated by the TH value and should not be adjusted.